



Material Handling USA

800-326-4403 | www.mh-usa.com



Borroughs
CORPORATION



Aisle-Saver[®]

Synergy Series[™]

The space-saving storage solution.

Save space. Make space.

Whether your operation is large or small, the demand for increased filing and storage capacity will eventually impact your operations by either reducing essential office space or demanding costly facility expansion or relocation. If your business, medical or law office, museum, library, healthcare facility, automotive shop, manufacturing or industrial facility is facing a crisis in filing or storage, it's time to save space and make space with Aisle-Saver.



High-density, space-saving and cost-saving storage solution: increase storage and filing capacity by 50%

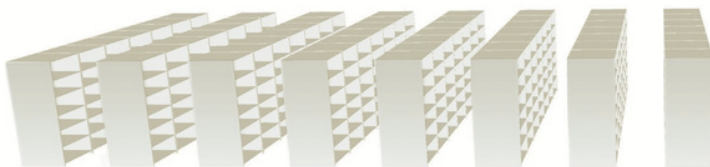

37'

Typical storage configuration

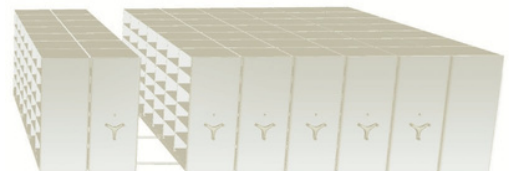

20'

Optimum storage configuration with Aisle-Saver® High Density Storage System

Protect important facility work space from being overrun by a growing demand for more and more storage. Use that space instead for critical office or facilities operations with Aisle-Saver®. Aisle-Saver is a flexible, high-density filing and storage system that can effectively double storage and filing capacity in existing facility space.

Aisle -Saver®

Flexible engineering. Responsive solutions.



This professional, aesthetically pleasing and easy-to-operate storage system offers improved filing and storage efficiency, accuracy and security to meet a wide range of storage demands from the corner office to the factory floor.



- Law Libraries
- Public & Private Libraries
- Health Care Facilities
- Government Offices
- Museums



- Universities
- Art Galleries
- Factories & Industrial
- Facilities Auto & Repair Shops

Moving design. Quality foundation.

Aisle-Saver's flexible design and optional features allows you to create exactly the storage and filing system your facility requires. The essential design and engineering features of every system are built to provide quality and reliable service for years to come.

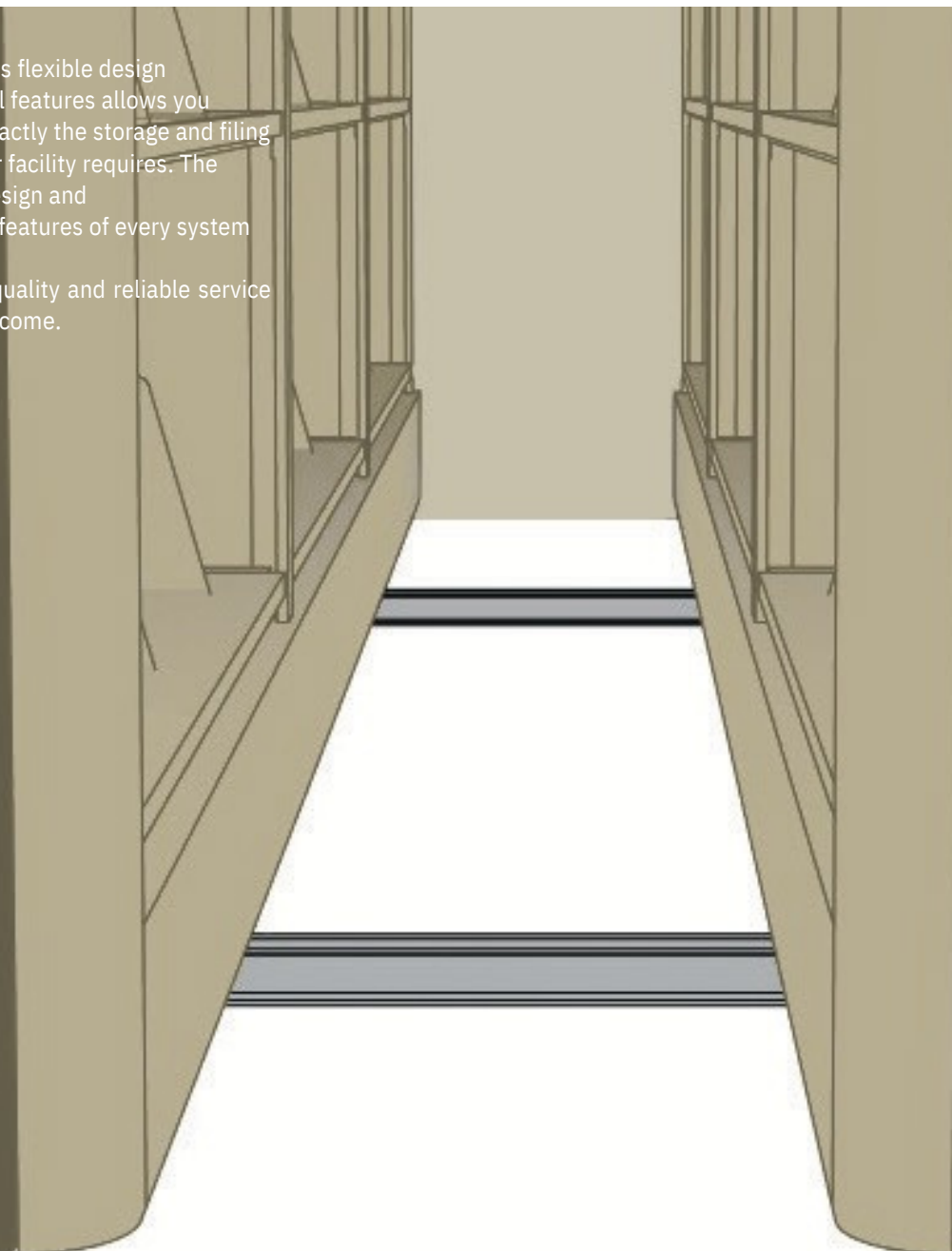



Synergy Series

Synergy Series

Synergy Series

Track Systems

Seismic Track
Systems

Carriage
Systems



- Track capacity is designed to carry maximum loads of 1,000 lbs. per linear carriage foot.

- Secured over-lapping track splice design provides positive vertical and horizontal alignment and even load transfer.

- Wheel-to-track $\frac{3}{4}$ " wide contact surface adds strength, durability, and smooth operation. Equal hardness of rail and wheels reduces wear.

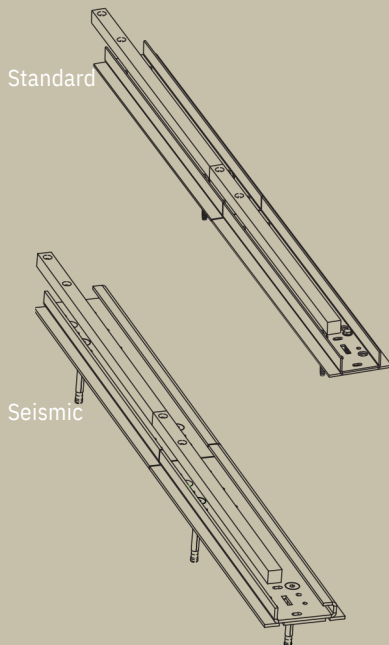

- Track mounted on top of the floor using an infill decking, or it is recessed in concrete. Filler-inserts create barrier-free access.

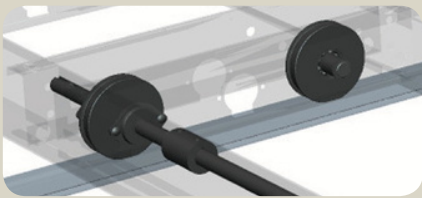

Synergy Series

Seismic Track Systems



- Seismic Track systems offer the same quality construction and design features as standard track systems, but are designed for application in high seismic zones.
- These tracks offer superior anti-tip protection by virtue of 10-gauge steel seismic gripper plates.



Safety Lock

Safety lock and the optional mechanical safety brake prevent aisle movement of mechanical Aisle-Saver systems while storage is being accessed. Additional key-operated lock options are also available for added security and ease of use.

Handle

Ergonomic handle design and powerful 6:1 drive ratios are capable of moving 6,000 lbs. with just 1lb. of pressure.

Wheels

All drive and guide wheels are 5" diameter and are precision machined from C1045 CRS steel. All wheels are double flanged with sealed, lifetime-lubricated bearings for superior durability and performance.

Carriage

Heavy-duty carriages are constructed of 12-gauge cold rolled steel with welded side channels, torsion channels, and cross-members for added strength and durability. Carriages are rated for maximum loads of 1,000 lbs. per linear carriage.

Track

Heavy-duty 12-gauge C1045 CRS steel construction matches wheel hardness to reduce wear and provide longer service life and optimal performance. Optional seismic track systems features 10-gauge steel seismic gripper plates.

Drive Axles

Full-length 1" steel drive shafts provide smooth carriage movement.

- Wheel-to-track $\frac{3}{4}$ " wide contact surface adds strength, durability, and smooth operation. Equal hardness of rail and wheels reduces wear.

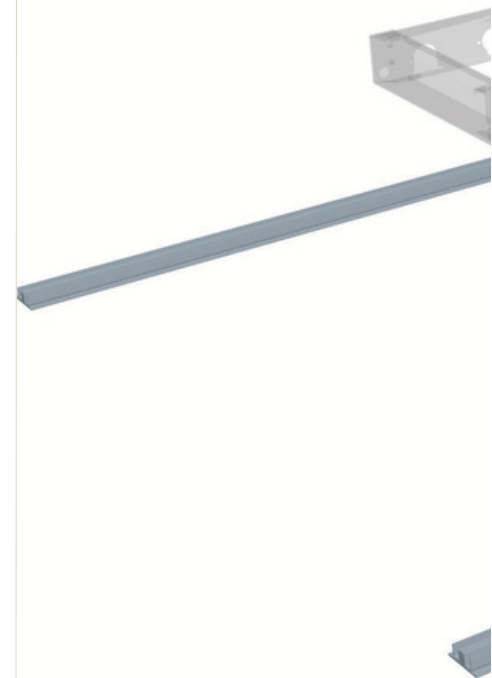

- Track can be recessed into flooring, decking, concrete, or mounted on top of floor. Secured over-lapping track splice design provides positive vertical and horizontal alignment and even load transfer.

Carriage Systems

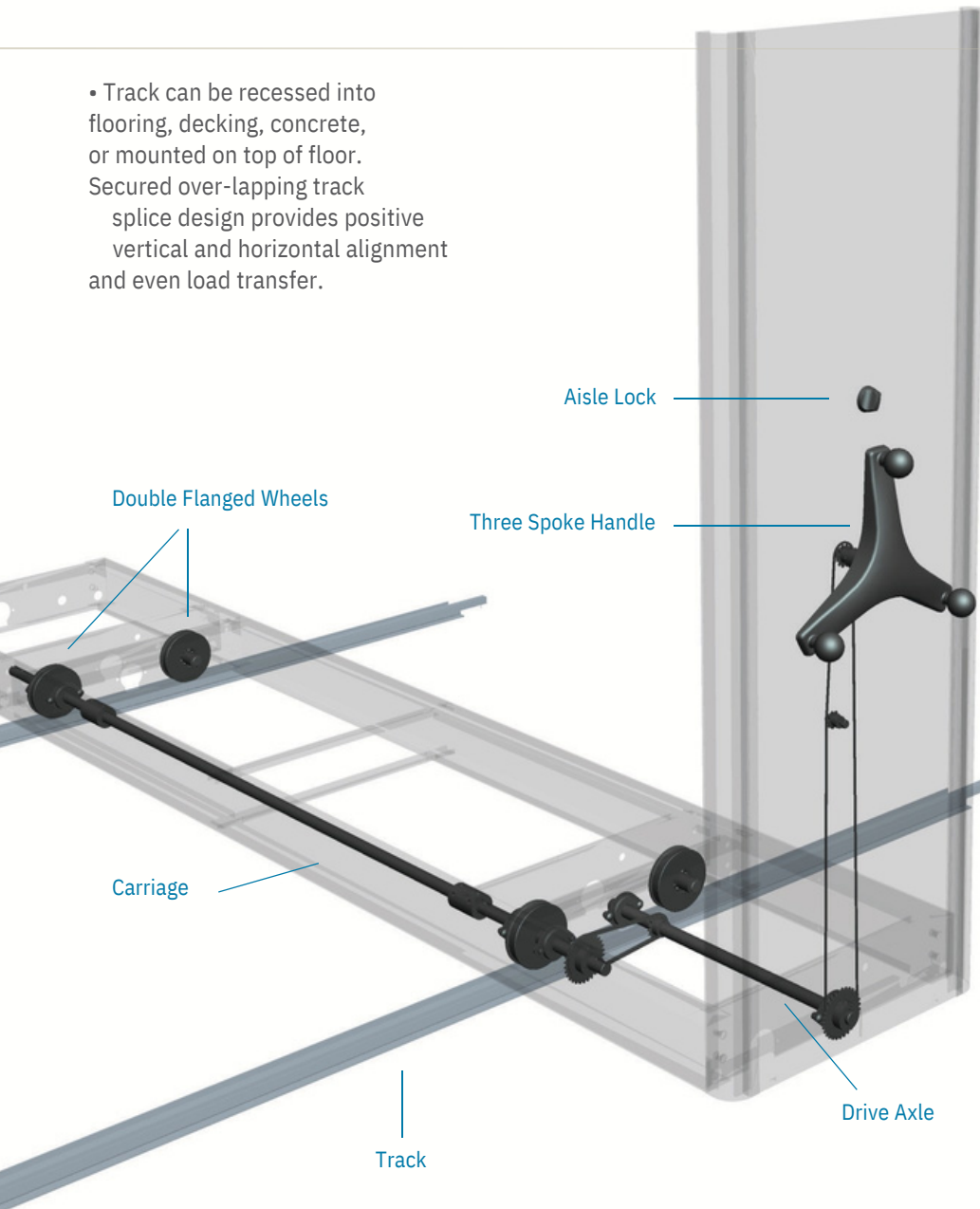

Mechanical Assist System

Synergy Series Electrical System

The Ultimate in Operational Safety and Security

The Aisle-Saver Synergy Series Electrical System offers the ultimate in operational efficiency, ease of use, as well as providing your facility with the industry standard in security and safety. Solid-state electronics, easy to read LCD Master Controller, featuring plug and play convenience, offers simple installation and programming.

- Simple control interface allows you to take immediate control and customize the system to meet your facility's specific needs for operational efficiency and security.
- Maintenance and system upgrades are simple and easy with little downtime and minimal cost.
- No limit switches or plunger to fail.
- The entire system draws only 12 volts and motors operate on just one-seventh of one horsepower.

- Soft Start technology prolongs motor life while protecting sensitive storage materials from abrupt starts and jarring motion.
- Sequential carriage movement reduces power consumption and energy costs.

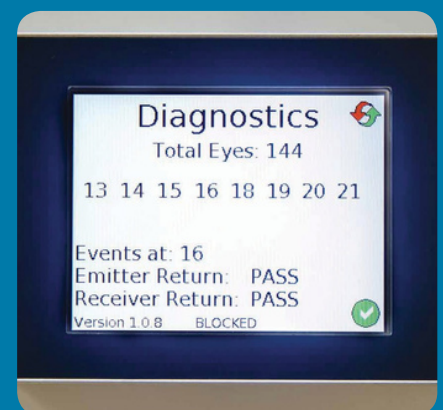

Heading

Light Carpet® Technology

Aisle-Saver's patented light carpet has provided users with reliable safety protection and security for over 15 years.

- Sensor beams are located on three inch centers, running the entire length of the carriage.
- Active/passive type of safety and security system.
- Simultaneously tracks multiple obstructions anywhere within the system to stop or prevent any movement of the carriage until everyone, and everything has left the system.

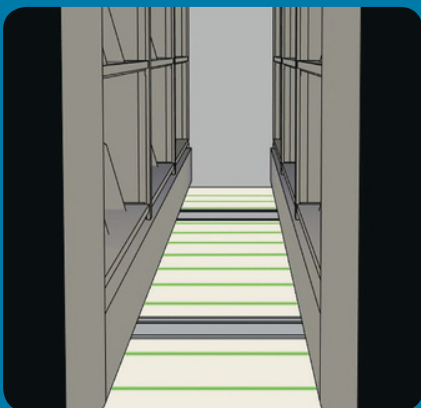

Synergy Series Mechanical Assist System

Time-Tested Simplicity and Durability

The Aisle Saver Synergy Series Mechanical Assist System allows you to effectively double your filing and storage capacity with all the quality and integrity of Aisle-Saver engineering in an easy to operate and efficient mechanical design.

- Ergonomic handle design and powerful 6:1 drive ratios are capable of moving 6,000 lbs. with just 1lb. of pressure.
- Safety lock for operator protection.
- Key-operated lock options available for added security.
- A variety of power coat finishes are available to complement any facility color scheme.
- Offered with optional mechanical safety brake.



Lateral Aisle-Saver Systems

Lateral Aisle-Saver Systems are the ideal solution for perimeter wall installations and applications. They may also be customized to fit any facility space or demand.

- Available in widths up to 48" and 18" depths.
- Double or triple row units.
- Custom fit for any facility application.
- Non-slip ramp and matting.



Color Options and Finishes

Create an Aisle-Saver system that perfectly complements the aesthetic value of your facility or office. Choose from a selection of standard Aisle-Saver colors. Ask about our custom wood or special finishes for unique applications. Aluminum handles are also available in different finishes and colors to match your individual décor.

Panel finishes

- High pressure laminate panels.
- Steel insert panels.
- Custom wood and special finishes also available.

Powdercoat Color Finishes

- Choose from nine standard colors, or...
- Choose your own unique powder coat color using our computer color matching.



Heights and Corners

- Full-height for maximum security and aesthetics.
- Half-height for versatility and increased visibility.
- Pedestal drive panels for economy and highest visibility (mechanical system application only).

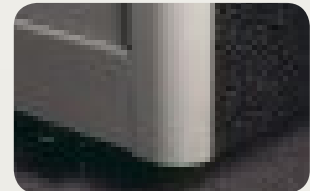

Radius Corner



Square Edge Corner

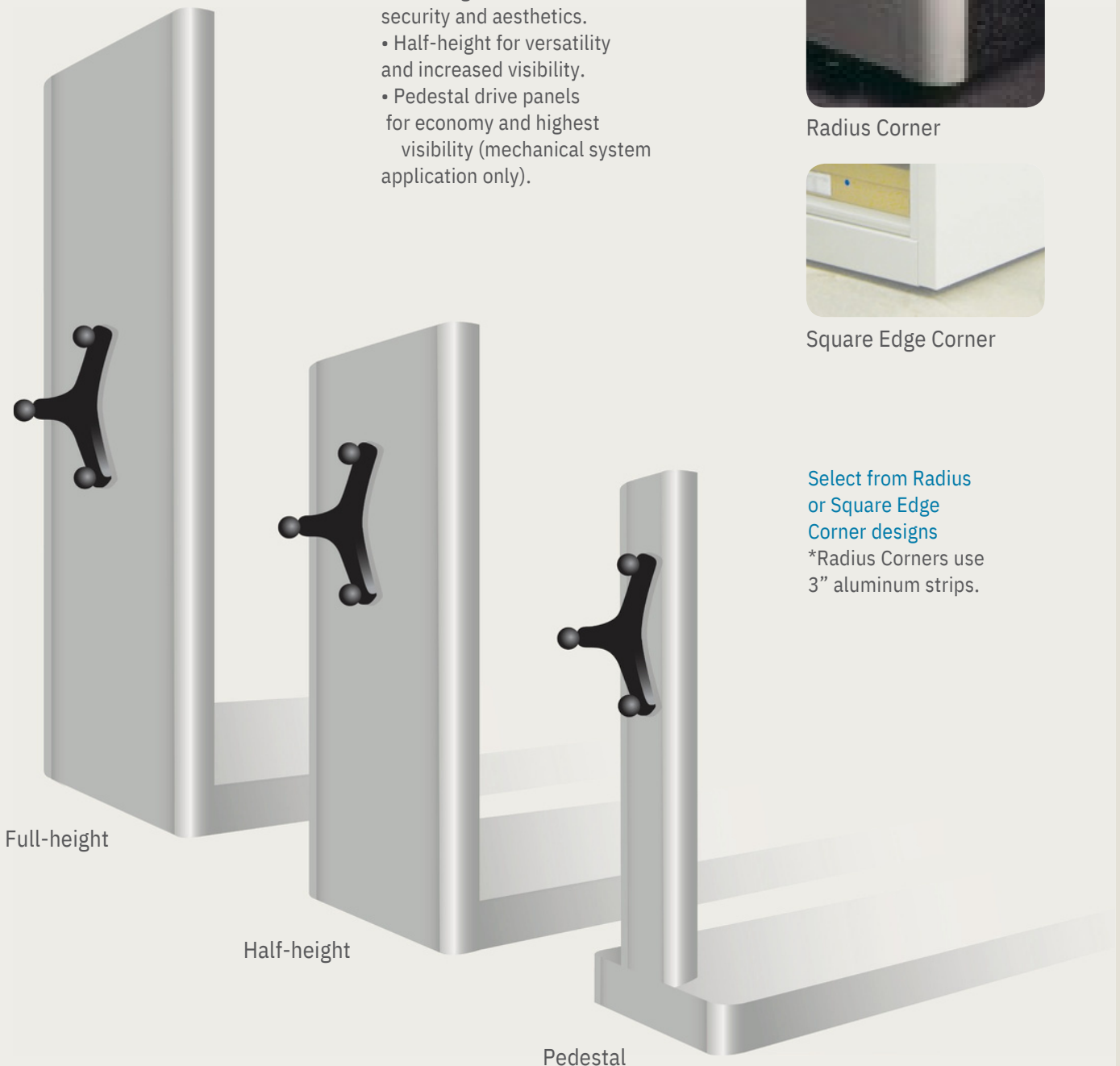

Select from Radius or Square Edge Corner designs

*Radius Corners use 3" aluminum strips.

Modular Options Flexible Solutions.

Choose the exact system configuration, filing system components, security options, colors, and finishes to improve the look, performance and efficiency of your facility.



Box-Edge Plus® Industrial Shelving

Ideal for general storage of large, heavy or bulky parts. Box-Edge Plus steel shelf construction features a closed, welded box shape design with welded corners for added rigidity, strength and impact resistance.

- High-Density Drawer Systems install easily.
- Open, closed, bin, ledge, cabinet and counter configuration options available.

High-Density Drawer Systems

Virtually unlimited partitioning and divider combinations allow you to design a system to improve space-efficiency as well as organizational productivity. Drawers protect storage from the environment while significantly improving retrieval time.

- Improves organization with hundreds of pre-configured or customized layouts.
- Cushion impact features a positive closing action that will not allow drawers to drift open.
- Label holders provide easy and fast identification.
- Full extension, 400 lb. capacity slides.



Rivet Span® Boltless Shelving

Economical, strong, and simple to assemble, Rivet Span offers a variety of beam choices to accommodate a wide range of loads, with spans and depths wider and deeper than conventional shelving choices.

- Accommodates storage of unusually large items.
- Widths up to 96" and depths up to 48".

Wilsonstak® Library Storage Systems

BorroughsWilsonstak shelving systems are the preferred choice of leading libraries, institutions and offices. Wilsonstak shelving allows you create a quality and durable shelving system that responds to your specific needs.

- Standard shelving units are adjustable and can be ordered in single or double face configurations.
- Choose from a wide range of heights and depths.
- Universal media shelving with 9" deep shelves and 5" high backs can be mounted in flat or sloped positions, with dividers, to accommodate a wide range of media storage requirements.
- Meets the need for storage requirements that call for flat, continuous surfaces.
- A wide range of accessories.

Record Master® Four-Post Shelving

Record Master provides a durable shelving and storage solution ideal for your office storage needs. Record Master's four-post, wedge-locking design can be assembled without nuts, bolts, or clips. The design provides excellent stability and capacity without requiring sway braces or gussets.

- Special Heavy-Duty Shelving designed for the high load capacity and protection, even suitable for X-rays.
 - Healthcare storage solutions for records, pharmacy, laboratory and research library filing and storage.
- ## Laboratory Cabinets

Designed to protect valuables, and used in conjunction with Aisle-Saver, these sealed cabinets expand



storage capacity while guarding significant investments in sensitive and fragile items.

- Vanguard closed-cell pure silicone gasket protects contents.
- Sealed, waterproof top.
- Non off-gassing, non-reactive, solvent free baked powder coat finish.
- Protective drawer bumper stop protects contents from sudden impact.





The Borroughs Corporation is dedicated to providing advanced, durable, and cost-effective storage solutions for today's leaders in industrial, manufacturing, retail, legal, business, healthcare, higher education, library, museum, and laboratory facilities and operations.

Reliable service. Total satisfaction.

Borroughs designs, engineers, and manufactures its shelving and storage solutions to maintain quality, and to respond directly to changes and new directions in the marketplace. On-site testing and design facilities allow Borroughs to work directly with customers to develop new concepts in storage that positively impact performance, productivity and cost-efficiency.

ISO 9001:2008 Certified

Sustainable processes. Environmentally responsible.

An environmentally responsible company, Borroughs continually looks for new and innovative ways to protect our environment. Our advanced powder coat process can reclaim paint from the atmosphere for reuse in later projects. If you are interested in taking part in our reclaimed paint program, contact your Borroughs representative and find out how you can partner with us in this environmentally responsible manufacturing process.

ISO 14001:2004 Certified





Working together. Moving forward.

Aisle-Saver® will double your storage capacity without expanding your facility or reducing space used for operations. Borroughs designers and engineers will create an Aisle-Saver system including shelving, drawers, bins, and cabinets, with electrical or manual options, to meet your exact needs. Call your Borroughs representative and discover how working together we can move your operational performance forward.





010 Autumn Haze

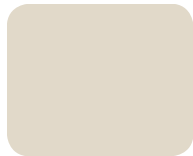

159 Eggshell

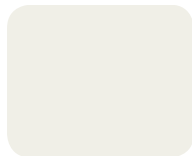

445 White



040 Black



161 Mist Gray

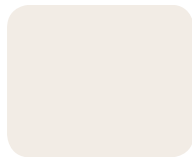

D492 Parchment



065 Industrial Gray



165 Forest Gray



F604 Pebble

- Aisle-Saver® Synergy Systems
- Aisle-Saver HD10®
- B-Span® Bulk Rack
- Box-Edge Plus® Industrial Storage
- Museum Storage Systems
- Record Master® Four-Post Shelving • Rivet Span® Boltless Shelving
- Wilsonstak® Library Storage
- High-Density Drawer Systems



800-326-4403 | www.mh-usa.com