

Material Handling USA

800-362-4403

LAB BENCHES AND ACCESSORIES



 **Material Handling USA**

222 S. Main St. 5th Floor, Salt Lake City, UT 84101 |
<https://www.mh-usa.com/> | 800-362-4403



Table of Contents

Page

Lab Benches	3
The Heart and Soul of the Laboratory	
Lab Bench Ergonomics	5
Concept Lab Bench	6
TL Advantage Lab Bench	12
Cornerstone Lab Bench	16
Heavy Duty Lab Bench	21
Accessories	24
Wall Shelving	32
Reagent Rack Systems	34
Lab Carts	36
Freedom of Mobility	
Lab Applications	38
Product Specifications / Technical Information	39



Heart and Soul of the laboratory

The lab bench is the main element of the laboratory. Other furnishings and accessories are assembled around it, creating a well-functioning lab. Lab benches are the ideal solution for a modern, state-of-the-art laboratory.



Lab benches provide the lab user with the highest quality and most flexible lab system, adapting to the demanding needs and changing equipment in the lab of today and tomorrow. Ergonomically our systems accommodate the necessary lab equipment while maintaining a safe and healthy work environment. They are robust and extremely flexible, easily adapting to individual needs, new equipment, and changes in environment or work. Carefully selected materials and ingenious design provide maximum durability, stability and usability even under maximum load.



Lab benches come in three standard depths of 24", 30", and 36", and five standard lengths of 40", 48", 60", 72", and 80". Casters may be installed to provide mobility for reconfiguration, cleaning, or repositioning. With the installation of uprights, the lab bench becomes a complete workstation with a multitude of accessories to choose from to customize each workspace.

The lab bench is the heart of the laboratory

Costs associated with health and safety problems are an ever increasing concern to all laboratories. This concern drives labs to seek solutions to provide a healthy, safe and productive working environment. Designing a workplace with ergonomics in mind improves the employee's well-being, which in turn improves productivity. Companies using correct ergonomic principles in the laboratory will reduce costs from injury and increase bottom line profits from increased productivity.

The modular design of lab benches enables proper ergonomics. With a wide range of accessories and

adjustments, customers are provided with a customized solution using standard components. Modularity and accessories are individually adjustable according to the task and human requirements.

Lab benches and accessories can be adjusted for operators of different heights working with left or right hand. Correctly adjusted workstations decrease stress in the muscles and enables productivity throughout the work day.

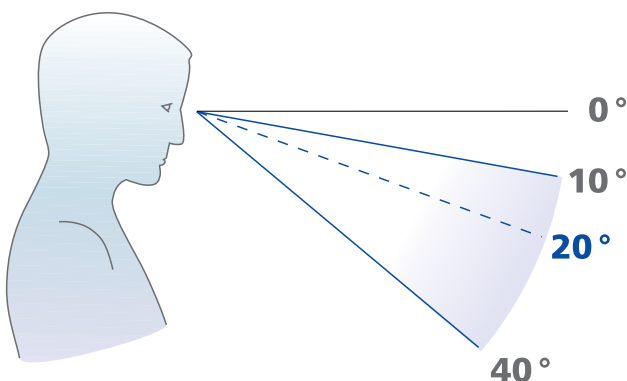

Location of the Correct View Angle

Focus point should follow these guidelines:

- Continual movement of view should be in 30 degree sector
- Continuous view angle should keep the head in a comfortable position (line of view should be 10 to 40 degrees below the horizontal line)
- Displays should be positioned 20 degrees below the horizontal line.

Lab Bench Ergonomics

Seated of Standup Work?

Decision of seated or standing work is dependent upon the work to be executed. The height of the worksurface is determined by such factors as size and weight of the part, precision need, assembly process, repetitiveness, etc. Differences in operator height require height adjustment for the work surface and accessories. Furthermore

correct leg space, optimal reach distances and directions provide optimal work movements and position for the operator. When designing the work space for a seated operation leg space should be at least 31.50" wide and 35.50" deep at floor level. For stand up work, leg space requirements are much less.

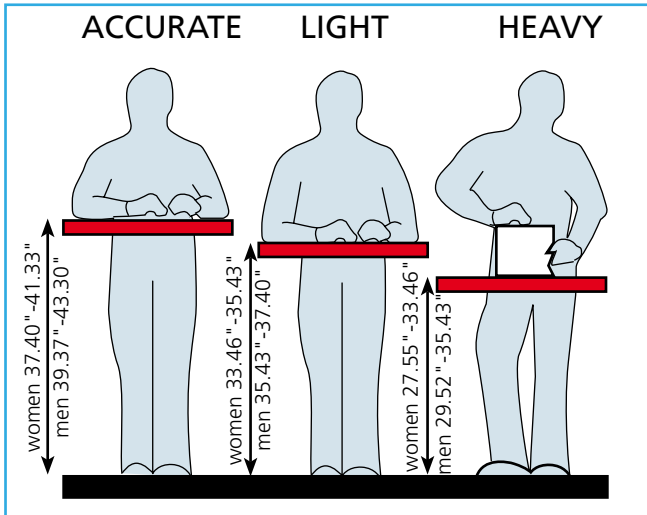

Standup work

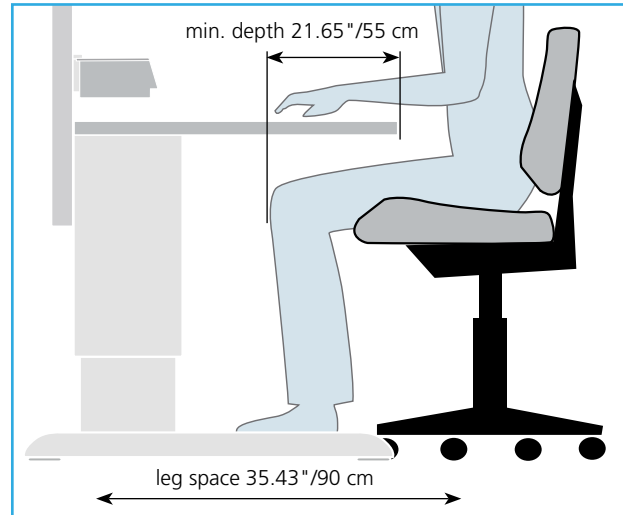

Seated work

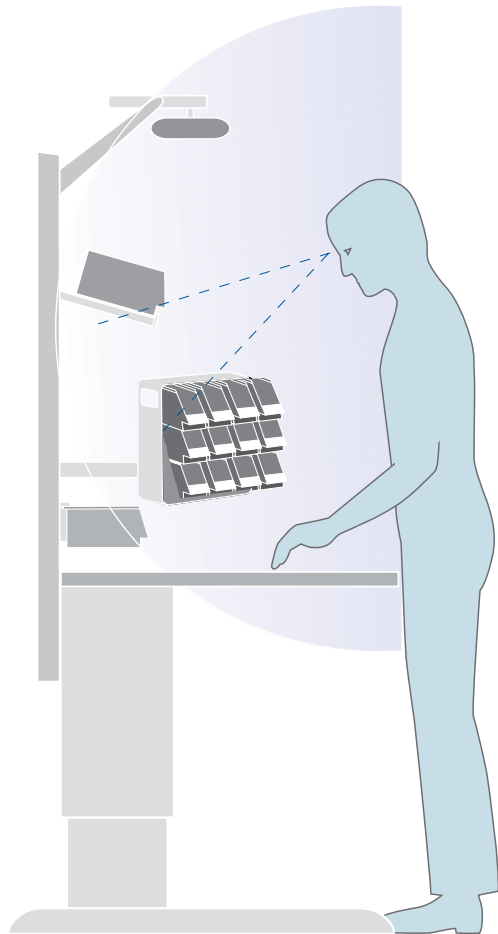

Reaching distances and heights

To improve working postures in assembly work, the most often used parts should be placed into the optimal horizontal working area within workers sight. Avoid overly large or deep tables, which can cause improper reach and reduced productivity. Assembly work is most ergonomic when parts are within easy view and reach.

The vertical work area and reach zone can be fine-tuned with accessories. Sovella's height adjustment arms optimize work movements and keep parts or tools within easy access. Operators can work with wrists and arms in optimal posture with shoulders relaxed. Tilted bin rails and shelves keep the wrist in a neutral position with picking parts. The tilt angle also provides easy identification of the parts with the proper viewing angle.

Utilizing proper reach distance can reduce the workstation foot print to optimize valuable factory real estate.

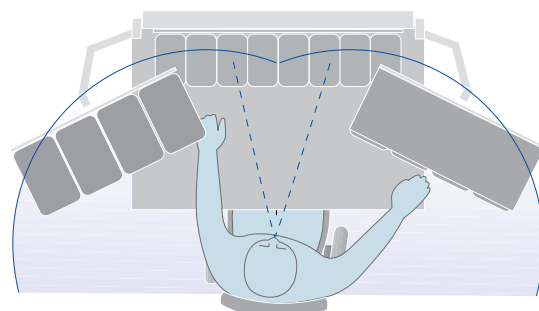

CONCEPT™ Lab Benches

Concept™ lab benches are designed for the needs of laboratory industries. There are many possible adjustments, all components fit together seamlessly, and each detail is designed for real world functionality. The lab bench adapts to the work process and the needs of the user. As a result all movements of the user can be optimized, which in

turn increases performance and productivity and decreases work-related stress.

Concept™ lab benches are height adjustable in manual, motorized and hand crank versions. All Concept™ frames can be equipped with casters to create mobile workstation solutions.



Three easy steps to design your Concept™ Lab Bench:

- 1** Select the bench frame size and the height adjustment method: manual, hand crank or motorized.
- 2** Select a worksurface to suit the frame: laminate, phenolic, or stainless.
- 3** Configure with accessories from page 34-61.

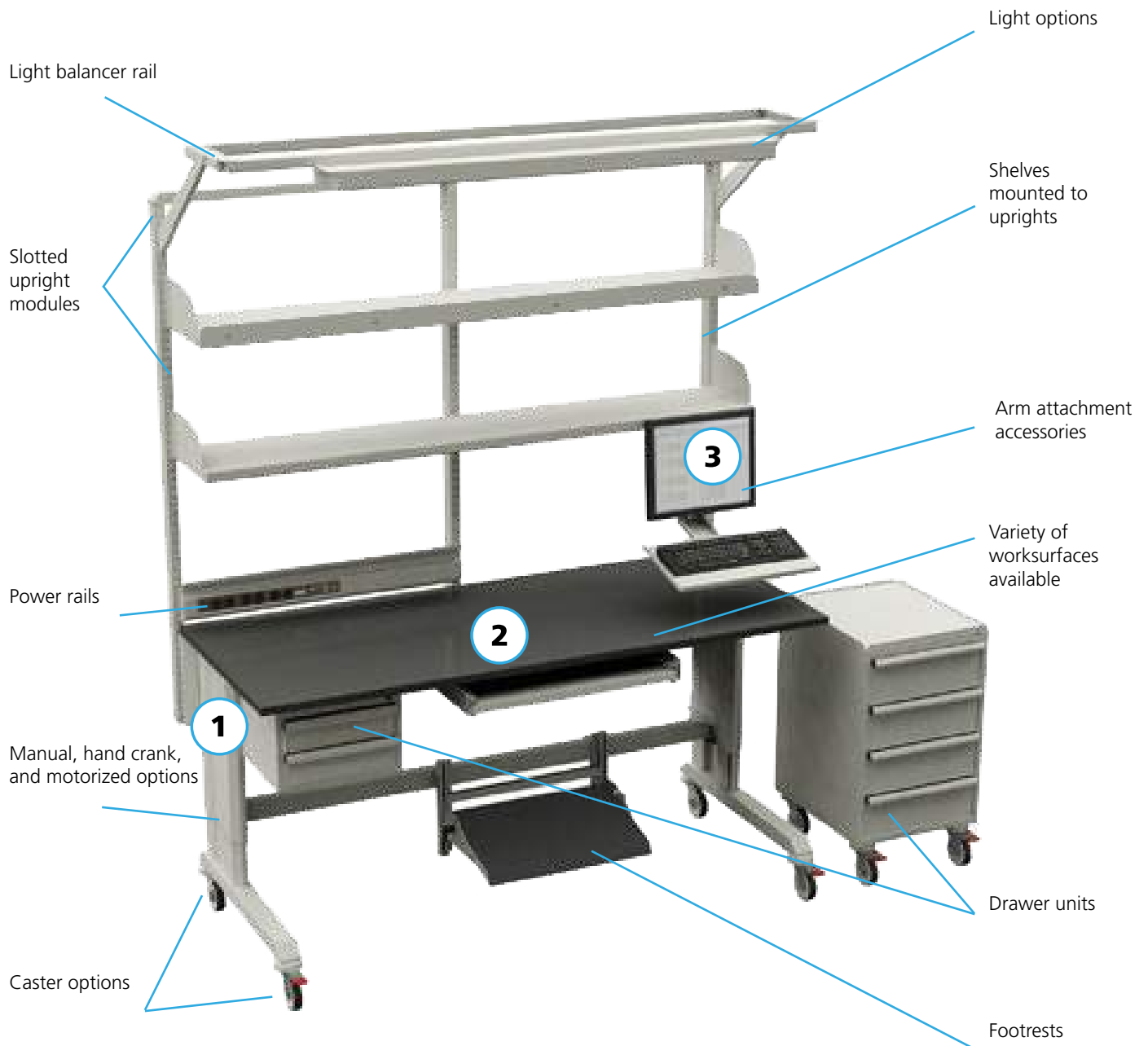

Concept™ Lab workstation

Order No C14-C10035174 •

Please see pages 34-61 for more accessory options.

1 Concept™ Lab Bench Frames

• = In stock products

1. Concept™ frames frame size W x D inches	Manual		Handcrank		Motor	
	order No	max load Lbs	order No	max load Lbs	order No	max load Lbs dynamic/static
30 x 31.5	14-10035123	440	14-1013557	440	14-1033546	660/1100
30 x 37.5	14-10035291	1100	E819146-35	440	14-10335257	660/1100
40 x 24	10035015	440	10135015	440	10335115	660/1100
40 x 30	10035030	1100	10135030	440	10335130	660/1100
40 x 36	14-1003562	1100	14-1013501	440	14-10335171	660/1100
48 x 24	10035016 •	440	10135016 •	440	10335116 •	660/1100
48 x 30	10035031 •	1100	10135031 •	440	10335131 •	660/1100
48 x 36	14-1003563	1100	14-1013502	440	14-10335172	660/1100
60 x 24	10035017	440	10135017	440	10335117	660/1100
60 x 30	10035032 •	1100	10135032 •	440	10335132 •	660/1100
60 x 36	14-1003565	1100	14-1013503	440	14-10335173	660/1100
72 x 24	10035018	440	10135018	440	10335118	660/1100
72 x 30	10035033 •	1100	10135033 •	440	10335133 •	660/1100
72 x 36	14-1003564	1100	14-1013504	440	14-10335174	660/1100
80 x 24	10035019	440			10335119	660/1100
80 x 30	10035034	1100			10335134	660/1100
80 x 36	14-10035145	1100			14-10335269	660/1100
Table height steplessly adjustable	26.62-44.34 inches		26.82-40.60 inches		27.80-43.55 inches	

All dimensions are nominal. See specific dimensions in the specification guide on page 117.
Height adjustment dimensions include glide and work top.

2. Concept™ corner bench frame

name	W x D inches	order No
Corner table frame for a standard table 24 inch deep	36 x 24	11135001
<i>60 x 24 main frame with 36 x 24 return frame</i>		
Corner table frame for a standard table 30 inch deep	42 x 24	11135002
<i>72 x 30 main frame with 42 x 24 return frame</i>		

3. Concept™ extension bench frame

name	W x D inches	order No
Extension table frame	59.05 x 23.62	11235001 •
Extension table frame	59.05 x 29.52	11235002 •
Extension table frame	71.10 x 29.52	11235003 •
Extension table frame	47.24 x 29.52	14-10035318



Additional dimensions and specifications available on page 117



Ergonomic sit and stand lab bench

Sit and stand lab benches are commonly used in testing and inspection. This is why the stroke of Sovella motor lab bench has been increased up to 15.75" inches. Now, the user's working position can be fixed ergonomically both in seated and standing work from 27.55 inches to 43.30 inches.

Intelligent control box

The new CBD4 control box can be programmed for several parameters: anti-collision, the minimum and maximum height and the speed. A tailor made parametering is programmed at the factory.



2 Concept™ worksurfaces

• = In stock products

Three standard choices of tops: postformed laminate, phenolic, and stainless steel.



Postformed laminate worksurface

Grey laminate usrface with postformed front edge
Thickness of 1 3/16 inches



Phenolic worksurface

Black phenolic...



Stainless steel worksurface

304 stainless wrapped over substrate
Thickness of 1 3/16 inches

The W x D x H rule
All our dimensions follow a WDH rule, where the first dimension is the width (W), the middle the depth (D), and the last the height (H).

Worksurfaces, postformed front

W x D inches	order No
40 x 24	14-9684102
48 x 24	14-9684103 •
60 x 24	14-9684104
72 x 24	14-9684105
80 x 24	14-9684106
40 x 30	14-9684109
48 x 30	14-9684110 •
60 x 30	14-9684111 •
72 x 30	14-9684112 •
80 x 30	14-9684113
40 x 36	14-9684116
48 x 36	14-9684117
60 x 36	14-9684118
72 x 36	14-9684119
80 x 36	14-9684120

Worksurfaces, phenolic

W x D inches	order No
40 x 24	
48 x 24	
60 x 24	
72 x 24	
80 x 24	
40 x 30	
48 x 30	14-9781805
60 x 30	14-9781806
72 x 30	14-9781807
80 x 30	
40 x 36	
48 x 36	
60 x 36	
72 x 36	
80 x 36	

Worksurfaces, stainless steel

W x D inches	order No
40 x 24	14-9660002
48 x 24	14-9660003
60 x 24	14-9660004
72 x 24	14-9660005
40 x 30	14-9660009
48 x 30	14-9660010
60 x 30	14-9660011
72 x 30	14-9660012
80 x 30	14-9660013
96 x 30	14-9660014
40 x 36	14-9660016
48 x 36	14-9660017
60 x 36	14-9660018
72 x 36	14-9660019
Stainless steel 304, No. 3 finish	

3 Accessories

See pages 34-61 for our wide range of workstation accessories.

Concept™ table color stripe pair

name	size inches	order No	color
Color stripe pair	20.86 x 3.14	860851-00 •	red
Color stripe pair	20.86 x 3.14	860853-00 •	blue

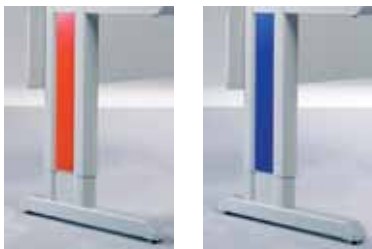

All Concept™ benches can be equipped with casters!

See page 34 for caster options.



description	order No
With ESD caster set	14-94035676
With non-ESD caster set	14-94041675
reduces starting height by 2" from standard starting height	

Help with moving

With a transport skate, one person can easily move tables.



Transport skate

Compatible with tables with a max depth of 29.52 inches.

description	max lbs	order No
Transport skate	396	854061-41
Transport skate ESD	396	854061-35

Preconfigured Concept™ Lab Benches

• = In stock products

This page illustrates assembled workstations that are easy to adapt for individual needs through the use of accessories on pages 34-61.



Concept™ manual lab bench

Order No 14-C10041120 •

Incl.

qty	description	size inches	order No
1	Frame - manual	59.05 x 29.52	10035032
1	Postformed worksurface	60 x 30	14-9684111



Concept™ motorized lab bench

Order No 14-C10341120 •

Incl.

qty	description	size inches	order No
1	Frame - motor	59.05 x 29.52	10335132
1	Postformed worksurface	60 x 30	14-9684111



Concept™ hand crank lab bench

Order No 14-C10141120 •

Incl.

qty	description	size inches	order No
1	Frame - handcrank	59.05 x 29.52	10135032
1	Postformed worksurface	60 x 30	14-9684111

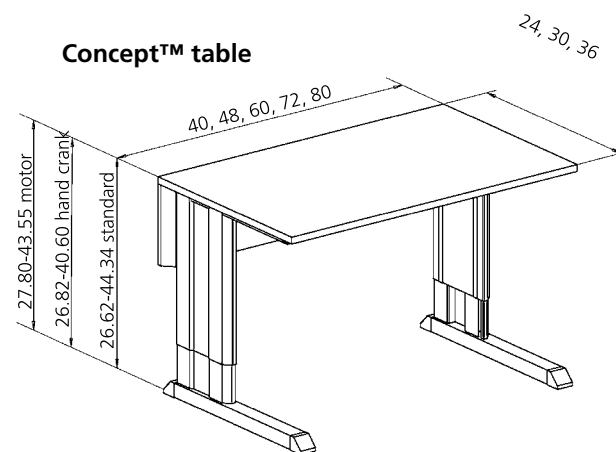

Please see product specification on page 117-118 for more dimensions.

Additional Sizes

Description	Size inches	order No
Concept™ manual frame w/worksurface	30x48	14-C10041121 •
Concept™ manual frame w/worksurface	30x72	14-C10041122 •
Concept™ motor table frame w/worksurface	30x48	14-C10341121 •
Concept™ motor table frame w/worksurface	30x72	14-C10341122 •
Concept™ crank table frame w/worksurface	30x48	14-C10141121 •
Concept™ crank table frame w/worksurface	30x72	14-C10141122 •



Concept™ Lab Bench Configuration 1

Order No 14-????????? •

Incl.

qty	description	size inches	order No
1	Frame - manual	59.05 x 29.52	10035032
1	Postformed worksurface	60 x 30	14-9684111
1	Upright module	2M36, 2X36"	90435001



Concept™ Lab workstation

Order No C14-C10035174 •

Incl.

qty	name	size inches	order No
1	Frame	72 x 30	10035033
1	Trespa Worksurface	72 x 30 x .75	14-9781807
1	Upright module	2M36, 2X36"	90435001
1	Drawer unit 38	2x3.94"	60535001
1	Drawer attachment set		860930-35
1	Bar Concept™	72	860083-35
1	Footrest, bar	21.65 x 13.77	860136-35
1	Light/balancer rail	2 x M36	91835008
1	Overhead light, 2 bulb	54	14-9503524
2	Steel Equipment shelf	72 x 11.81	854482-35
2	Shelf lip	72	14-94035294
2	Bookend brackets, pair	12"	E815050-35
1	Horizontal bin rail, 6 outlet power w/surge, 36"		14-9113511
1	LCD monitor arm		93035002
1	Keyboard tray for LCD holder	18.89" x 10.23"	860841-35
1	Under surface keyboard shelf	24.8" x 15.74"	92535001
1	Base unit 45 drawer, 4-5.9" drawers	18" x 22" x 30"	60735304
1	4" Caster set, 2 locking, 2 non-locking	4"	834734-00

Concept™ Lab Bench Configuration 2

Order No 14-????????? •

Incl.

qty	description	size inches	order No
1	Frame - manual	59.05 x 29.52	10035032
1	Postformed worksurface	60 x 30	14-9684111
1	Upright module	2M36, 2X36"	90435001
2	Steel Equipment shelf	72 x 11.81	854482-35

TL ADVANTAGE™ lab bench

TL Advantage™ lab benches are well suited for a variety of laboratory applications. TL Advantage™ utilizes an industry-exclusive standard ESD Semi-Conductive paint (proprietary process) and can be outfitted with a plethora of standard accessories. With its incredible strength, flexibility, and durability,

the TL Advantage™ lab bench is the most cost effective ergonomic lab bench solution on the market today. Benches are available in 6 widths, stationary and mobile configurations, and are easily assembled with 4 simple tools.

Three easy steps to design your own TL Advantage™ lab bench:

- 1** Select a single-sided or double-sided frame size and/or frame extension.
- 2** Select a worksurface to suit the frame: plastic laminate or phenolic.
- 3** Configure with accessories from pages 34-61.

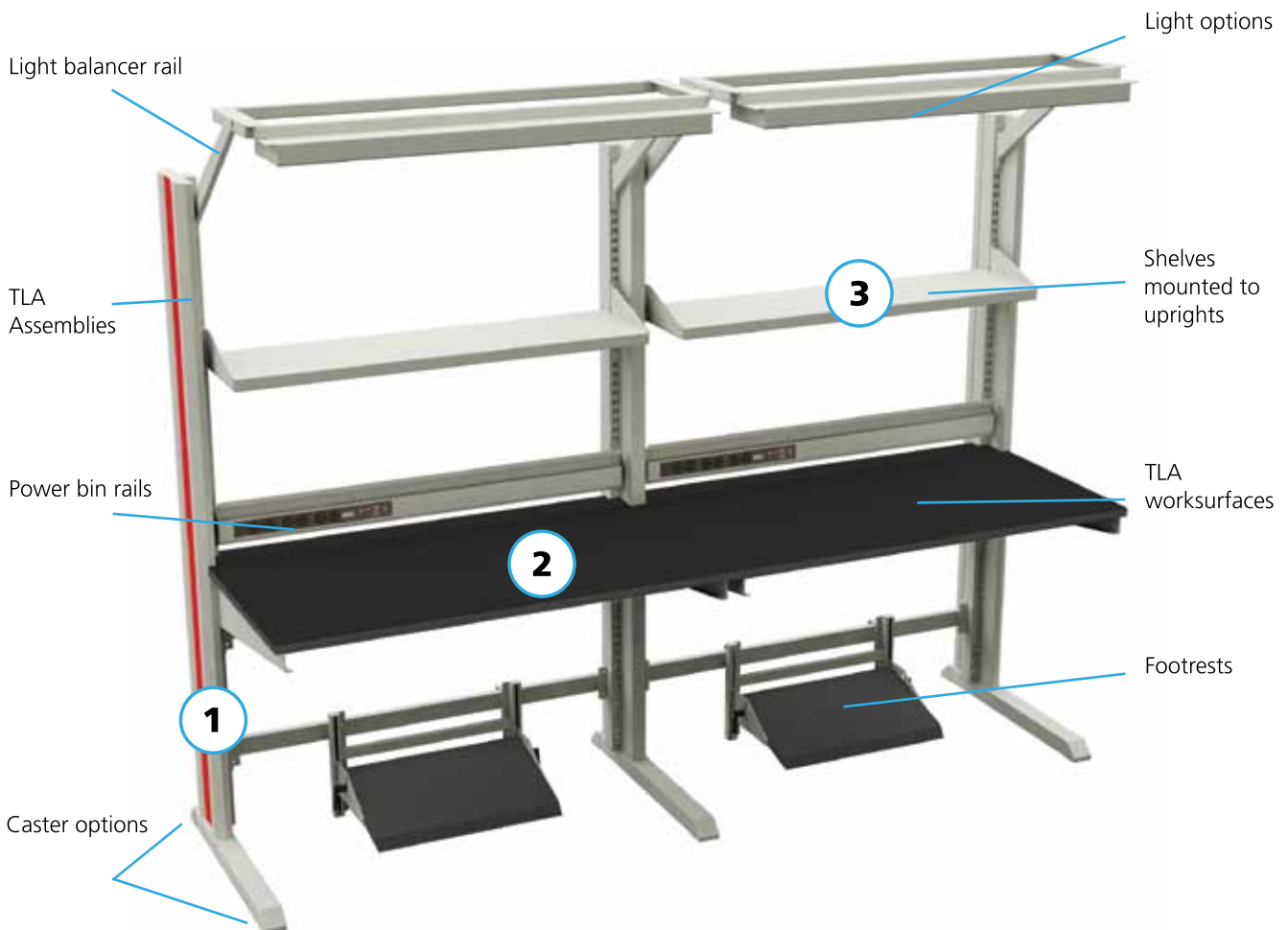

1 TL Advantage™ Frames

• = In stock products

1. TL Advantage™ Single-Sided Starter Assemblies 2-75.59" H Upright Columns, 2 Spacer Bars

Order No.	Configuration
14-C12535352	TL Advantage™ 30"W x 75.59"H Single-Sided Starter Assembly
14-C12535353	TL Advantage™ 36"W x 75.59"H Single-Sided Starter Assembly
14-C12535354	TL Advantage™ 48"W x 75.59"H Single-Sided Starter Assembly
14-C12535355	TL Advantage™ 53"W x 75.59"H Single-Sided Starter Assembly
14-C12535356	TL Advantage™ 60"W x 75.59"H Single-Sided Starter Assembly
14-C12535357	TL Advantage™ 72"W x 75.59"H Single-Sided Starter Assembly

2. TL Advantage™ Single-Sided Add On Assemblies 1-75.59" H Center Upright Column, 2 Spacer Bars

Order No.	Configuration
14-C12535358	TL Advantage™ 30"W x 75.59"H Single-Sided Add On Assembly
14-C12535359	TL Advantage™ 36"W x 75.59"H Single-Sided Add On Assembly
14-C12535360	TL Advantage™ 48"W x 75.59"H Single-Sided Add On Assembly
14-C12535361	TL Advantage™ 53"W x 75.59"H Single-Sided Add On Assembly
14-C12535362	TL Advantage™ 60"W x 75.59"H Single-Sided Add On Assembly
14-C12535363	TL Advantage™ 72"W x 75.59"H Single-Sided Add On Assembly

3. TL Advantage™ Double-Sided Starter Assemblies 2-75.59" H Upright Columns, 2 Spacer Bars

Order No.	Configuration
14-C12535364	TL Advantage™ 30"W x 75.59"H Double-Sided Starter Assembly
14-C12535365	TL Advantage™ 36"W x 75.59"H Double-Sided Starter Assembly
14-C12535366	TL Advantage™ 48"W x 75.59"H Double-Sided Starter Assembly
14-C12535367	TL Advantage™ 53"W x 75.59"H Double-Sided Starter Assembly
14-C12535368	TL Advantage™ 60"W x 75.59"H Double-Sided Starter Assembly
14-C12535369	TL Advantage™ 72"W x 75.59"H Double-Sided Starter Assembly

4. TL Advantage™ Double-Sided Add On Assemblies 1-75.59" H Center Upright Column, 2 Spacer Bars

Order No.	Configuration
14-C12535370	TL Advantage™ 30"W x 75.59"H Double-Sided Add On Assembly
14-C12535371	TL Advantage™ 36"W x 75.59"H Double-Sided Add On Assembly
14-C12535372	TL Advantage™ 48"W x 75.59"H Double-Sided Add On Assembly
14-C12535373	TL Advantage™ 53"W x 75.59"H Double-Sided Add On Assembly
14-C12535374	TL Advantage™ 60"W x 75.59"H Double-Sided Add On Assembly
14-C12535375	TL Advantage™ 72"W x 75.59"H Double-Sided Add On Assembly

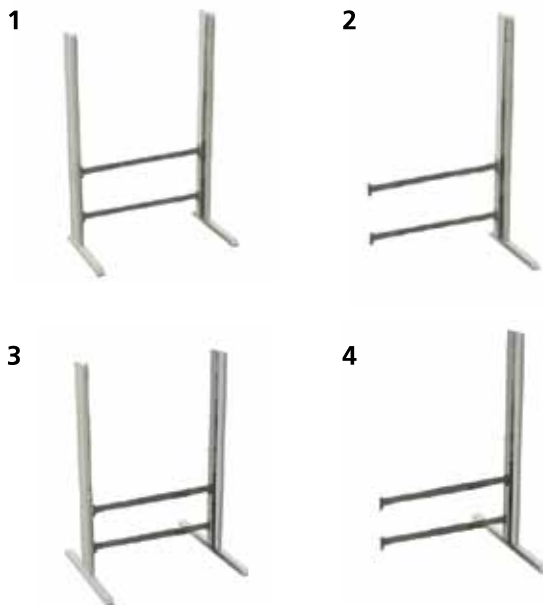

Module size

The module (M) size refers to the distance between two upright tubes from the middle of the tube. The module size is used to find the appropriate accessories.

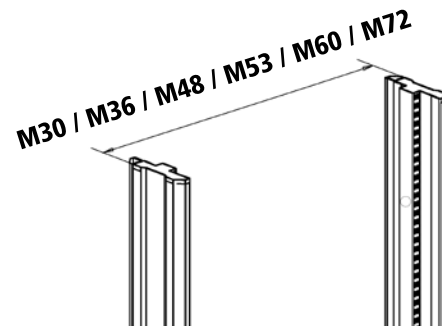

Upper/Lower Steel Shelves

Order No.	Configuration
836028-35	Steel shelf w/ lip, M30 x 12", 110 lbs capacity, 0° or 20° angle
852770-35	Steel shelf w/ lip, M30 x 16", 110 lbs capacity, 0° or 20° angle
852283-35	Steel shelf w/ lip, M36 x 12", 110 lbs capacity, 0° or 20° angle
852769-35	Steel shelf w/ lip, M36 x 16", 110 lbs capacity, 0° or 20° angle
854480-35	Steel shelf, M48 (45.94") x 11.81", 176 lbs capacity
854483-35	Steel shelf, M48 (45.94") x 15.74", 176 lbs capacity
860787-35	Steel shelf w/ lip, M53 x 11.81", 110 lbs capacity, 0° or 20° angle
860788-35	Steel shelf w/ lip, M53 x 15.74", 110 lbs capacity, 0° or 20° angle
854481-35	Steel shelf, M60 (57.75") x 11.81", 176 lbs capacity
854484-35	Steel shelf, M60 (57.75") x 15.74", 176 lbs capacity
854482-35	Steel shelf, M72 (69.80") x 11.81", 176 lbs capacity
854485-35	Steel shelf, M72 (69.80") x 15.74", 176 lbs capacity

Cable management in TL Advantage™ lab bench

The leg of the TL Advantage™ bench can include integrated power to organize utilities.

• = In stock products

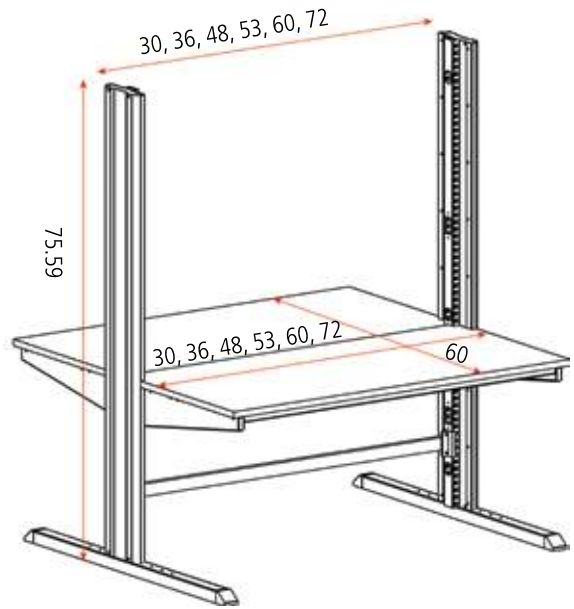
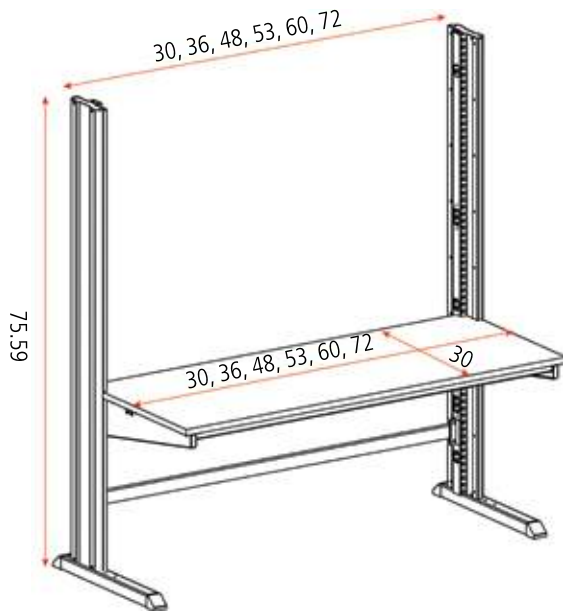

Additional dimensions and specifications available on page 119

2

TL Advantage™ worksurfaces



Laminate worksurface
Light-grey laminate surface
Thickness of 3/4 inches



Phenolic worksurface
Black phenolic...



TL Advantage™ bench top assembly

Table top assembly includes worksurface, support brackets, and horizontal rails.

size W x D (inches)	laminate top order No	phenolic order No
30 x 30	14-C12535328	14-
36 x 30	14-C12535329	14-
48 x 30	14-C12535330	14-9781805
53 x 30	14-C12535331	14-
60 x 30	14-C12535332	14-9781806
72 x 30	14-C12535333	14-9781807

3

TL Advantage™ Accessories

The TL Advantage™ lab bench upright has the same slots as the upright tubes. Therefore the TL Advantage™ bench can be equipped with the same accessories as other Sovella benches. Use the arm holder extension arm to attach articulating arm components.



TL Advantage™ arm holders

name	order No
holder extension for large arm	861099-35

All Concept™ tables can be equipped with casters!

See page 34 for caster options.



Color stripes

Color can be added to the sides of TL Advantage™ table legs with plastic color stripes. There are two standard colors: blue and red. The color stripes have to be ordered separately.



TL Advantage™ table color stripe pair

size	order No	color
72" x 3.14"	E819285-00	blue
72" x 3.14"	E819287-00	red



Utilities can be easily integrated into TL Advantage uprights with optional power and data outlets.



Sovella TL Advantage Pre-Configured Single Sided Starter Work Station 75.59" H

Configuration	Item No.
TL Advantage SSS 48"W x 30" D w/ Steel Shelf, 6 outlet power, 2-Bulb Light, foot rest w/ PF Laminate	14-C12541302
TL Advantage SSS 60"W x 30" D w/ Steel Shelf, 6 outlet power, 2-Bulb Light, foot rest w/ PF Laminate	14-C12541304
TL Advantage SSS 72"W x 30" D w/ Steel Shelf, 6 outlet power, 2-Bulb Light, foot rest w/ PF Laminate	14-C12541305



Sovella TL Advantage Pre-Configured Single Sided Add On Work Station 75.59" H

Configuration	Item No.
TL Advantage SSA 48"W x 30" D w/ Steel Shelf, 6 outlet power, 2-Bulb Light, foot rest w/ PF Laminate	14-C12541308
TL Advantage SSA 60"W x 30" D w/ Steel Shelf, 6 outlet power, 2-Bulb Light, foot rest w/ PF Laminate	14-C12541310
TL Advantage SSA 72"W x 30" D w/ Steel Shelf, 6 outlet power, 2-Bulb Light, foot rest w/ PF Laminate	14-C12541311



Sovella TL Advantage Pre-Configured Double Sided Starter Work Station 75.59" H

Configuration	Item No.
TL Advantage DSS 48"W x 30" D w/ Steel Shelf, 6 outlet power, 2-Bulb Light, foot rest w/ PF Laminate	14-C12541314
TL Advantage DSS 60"W x 30" D w/ Steel Shelf, 6 outlet power, 2-Bulb Light, foot rest w/ PF Laminate	14-C12541316
TL Advantage DSS 72"W x 30" D w/ Steel Shelf, 6 outlet power, 2-Bulb Light, foot rest w/ PF Laminate	14-C12541317



Sovella TL Advantage Pre-Configured Double Sided Add On Work Station 75.59" H

Configuration	Item No.
TL Advantage DSA 48"W x 30" D w/ Steel Shelf, 6 outlet power, 2-Bulb Light, foot rest w/ PF Laminate	14-C12541320
TL Advantage DSA 60"W x 30" D w/ Steel Shelf, 6 outlet power, 2-Bulb Light, foot rest w/ PF Laminate	14-C12541322
TL Advantage DSA 72"W x 30" D w/ Steel Shelf, 6 outlet power, 2-Bulb Light, foot rest w/ PF Laminate	14-C12541323

Cornerstone™ Lab Benches

Cornerstone™ lab benches are standard tables that are suitable for a broad range of laboratory tasks. The Cornerstone™ bench is guaranteed for regular use with weights up to 1500 Lbs. This degree of strength

is achieved by using a solid table structure. The Basic™ upright bench is ideal for lighter use, when some additional workspace is needed. The slotted upright frame allows for the use of different accessories.



Manual height adjustment

The height of our Cornerstone™ range can be adjusted from 24.75 to 37.64 inches, in 1 inch increments, making these benches suitable for work while sitting or standing.

Three easy steps to design your own Cornerstone™ or Basic™ Upright Lab Bench:

- 1 Select the table frame: Cornerstone™ lab bench or Basic™ upright bench.
- 2 Select a worksurface to suit the frame.
- 3 Equip with accessories from page 34-61.



Cornerstone™ Lab bench

Order No C 14-????? •

Please see pages 34-61 for more accessory options.

1 Cornerstone™ Lab Bench Frames

• = In stock products

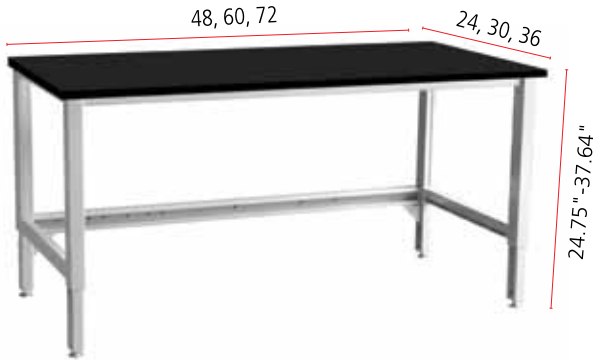

Please see product specification on page 119 for more dimensions.

Cornerstone™ lab bench frame

bench frame W x D inches	max Lbs	order No
48 x 24	1500	14-12035140
60 x 24	1500	14-12035141
72 x 24	1500	14-12035142
48 x 30	1500	14-12035135 •
60 x 30	1500	14-12035136 •
72 x 30	1500	14-12035138 •
48 x 36	1500	14-12035143
60 x 36	1500	14-12035137
72 x 36	1500	14-12035139

The height is adjustable from 24.75 to 37.64 inches including glide and top.



Basic™ upright frame

size W x H inches	max Lbs	order No
M20 x 70.86	220	14-85035101
M30 x 70.86	220	14-85035103 •
M36 x 70.86	220	14-85035105 •

See page 21 for worksurface information.

Basic™ upright frame components

name	size inches	max Lbs	order no.
Bracket pair		132	860 139-35 •
"L" Bracket Set - worksurface right			14-94035228
"L" Bracket Set - worksurface left			14-94035229
A Foot extension	7"		890317-35 •
A Foot extension	17"		890247-35 •

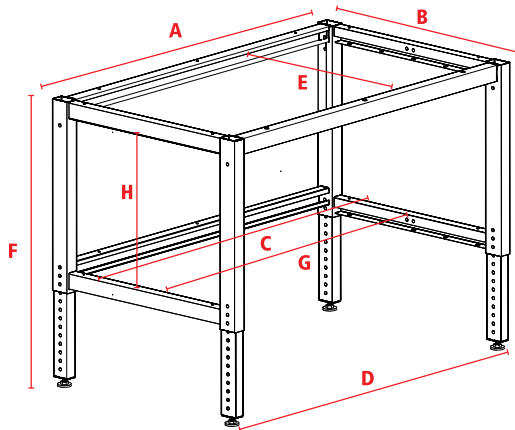

The Cornerstone™ table frame has module sized spacing between mounting locations for the slotted uprights. 63" height slotted uprights are the only applicable upright for use on Cornerstone™ frames.

Frame Dimensions			
	30x48	30x60	30x72
	14-12035135	14-12035136	14-12035138
A	45.81"	57.63"	69.44"
B	27.69"	27.69"	27.69"
C	43.13"	54.95"	66.75"
D	44.19"	56"	67.81"
E	24.25"	24.25"	24.25"
F	23.5-36.39"	23.5-36.39"	23.5-36.39"
G	45.5"	57.31"	69.13"
H	20"	20"	20"

Cornerstone™ Frame - no casters

Size	Frame Only	Frame only w/ Drawer Brackets - 1 Drawer	Frame only w/ Drawer Brackets - 2 Drawers
30 x 48	14-12035135	14-12035185	14-12035188
30 x 60	14-12035136	14-12035186	14-12035189
30 x 72	14-12035138	14-12035187	14-12035190

Cornerstone™ Frame - w/ casters

Size	Frame only w/ Casters	Frame only w/ casters - 1 Drawer	Frame only w/ casters - 2 Drawers
30 x 48	14-10035426	14-12035191	14-12035194
30 x 60	14-10035427	14-12035192	14-12035195
30 x 72	14-10035428	14-12035193	14-12035196

2 Cornerstone™ worksurfaces

• = In stock products



Postformed worksurface

Grey laminate surface
Postformed front edges
Thickness of 1 3/16 inches



Phenolic worksurface

Black phenolic...

Worksurfaces

bench frame size W x D inches	Postformed order No	Phenolic order No
40 x 24	14-9684102	14-
48 x 24	14-9684103 •	14-
60 x 24	14-9684104	14-
72 x 24	14-9684105	14-
40 x 30	14-9684109	14-
48 x 30	14-9684110 •	14-9781805
60 x 30	14-9684111 •	14-9781806
72 x 30	14-9684112 •	14-9781807
40 x 36	14-9684116	14-
48 x 36	14-9684117	14-
60 x 36	14-9684118	14-
72 x 36	14-9684119	14-

See additional worksurface options on pages 11 & 26.

3 Accessories

See pages 34-61 for our wide range of bench accessories.

Slotted Upright Kits

Kit Size	Name	Order No
1 x M48	Single Bay upright kit	14-907350
1 x M60	Single Bay upright kit	14-9073512
1 x M72	Single Bay upright kit	14-9073513
2 x M30 (60")	Double Bay 2-30" upright kit for 60" frame	90335002 •
2 x M36 (72")	Double Bay 2-36" upright kit for 72" frame	90435002 •

Additional upright options available on page 35.

Drawer Mounting Brackets

Name	Size	Order No
Drawer bracket pair	24"	E820347-35
Drawer bracket pair	30"	E820348-35 •
Drawer bracket pair	36"	E820349-35

Drawer brackets will support third party drawer units.

Lower shelves for the Cornerstone™ bench

name	Bench Width	W x D inches	max Lbs	order No
Lower steel equipment shelf	48	45.94 x 11.81	176	14-1203576 •
Lower steel equipment shelf	48	45.94 x 15.74	176	14-1203579 •
Lower steel equipment shelf	60	57.75 x 11.81	176	14-1203577 •
Lower steel equipment shelf	60	57.75 x 15.74	176	14-1203580 •
Lower steel equipment shelf	72	69.80 x 11.81	176	14-1203578 •
Lower steel equipment shelf	72	69.80 x 15.74	176	14-1203581 •

Lower Packaging shelves for use with tube dividers

name	Bench Width	W x D inches	max lbs	order No
Lower packaging shelf	48	45.94 x 15.74	176	14-1203587 •
Lower packaging shelf	60	57.79 x 15.74	110	14-1253588 •
Lower packaging shelf	72	69.80 x 15.74	110	14-1203589 •
Tube dividers set (4 pcs)		ø .62 x 13.22 x 11.81		859010-35

Optional Bottom Shelf

Bottom shelf can be added to the Cornerstone™ lab bench, providing storage underneath the work surface.



Optional Packaging Shelf Dividers



Upright attachment bracket included with workstation frame.

All Cornerstone™ benches can be equipped with casters!

See page 34 for caster options.



Preconfigured Cornerstone™ Workstations

This page illustrates assembled workstations that are easy to adapt for individual needs through the use of accessories on pages 34-61.



Cornerstone™ Laboratory workstation

Order No 14-C12041203

Incl.

qty	name	size inches	order No
1	Frame	59.05 x 29.52	14-12035136
1	Trespa worksurface	60 x 30 x .75	14-9781806
1	M60 slotted upright module	M60 x 63	14-9073512
1	Steel equipment shelf	M60 x 11.81	854481-35
1	Bookend bracket pair	12"	E815050-35
1	Steel equipment shelf	M60 x 15.74	854484-35
1	Bookend bracket pair	16"	E816296-35
1	Power rail w/ 6 outlet power bar	M60	14-9113519
1	Drawer unit 75/56 double door w/ lock and casters		60835306



Cornerstone™ Laboratory workstation 2

Order No 14-C???????

Incl.

qty	name	size inches	order No
1	Frame	59.05 x 29.52	14-12035136
1	Trespa worksurface	60 x 30 x .75	14-9781806
1	M60 slotted upright module	M60 x 63	14-9073512
1	Steel equipment shelf	M60 x 11.81	854481-35
1	Bookend bracket pair	12"	E815050-35
1	LCD monitor arm, double articulating arm		93035002
1	CPU holder leg mount, 3.94-9.49 x 17.71 x 1.96		860553-35

Cornerstone™ Laboratory workstation 3

Order No 14-C12041203

Incl.

qty	name	size inches	order No
1	Frame	59.05 x 29.52	14-12035136
1	Trespa worksurface	60 x 30 x .75	14-9781806
1	M60 slotted upright module	M60 x 63	14-9073512
1	Steel equipment shelf	M60 x 11.81	854481-35
1	Bookend bracket pair	12"	E815050-35
1	Steel equipment shelf	M60 x 15.74	854484-35
1	Bookend bracket pair	16"	E816296-35
1	Power rail w/ 6 outlet power bar	M60	14-9113519
1	Footrest with massage roller	19.69x14.57x3.94	JT2
1	Series X 30 chair, red	16.73-22.24"H	X30R



Four easy steps to design your Workshop™ workstation:

- 1 Select the appropriate worksurface: steel, PVC, maple, ShopTop or laminate.
- 2 Select a support for both ends of the worksurface: adjustable or fixed leg, or a drawer unit.
- 3 Use a spacer bar to stabilize the table. An upright attachment frame can be used instead of a spacer bar if upright tubes are used.
- 4 Equip with accessories from pages 34-61.

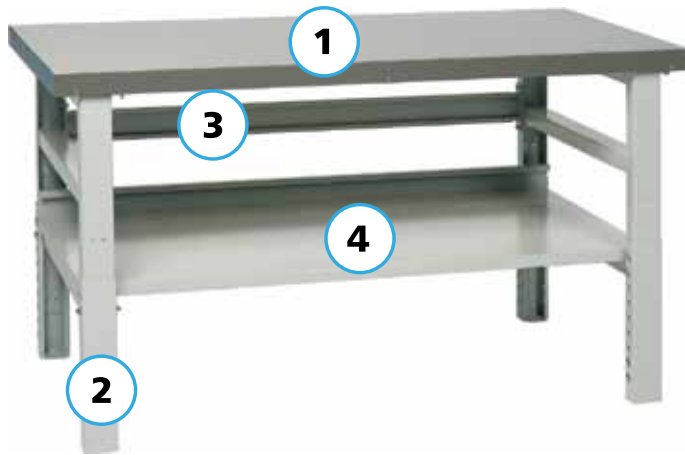

Heavy Duty Steel Workstation Table

Order No 14-C1304128

Name	Size inches	Load Cap.	Order No.
Adjustable legs (2)	27.55-37.40		836664-35
Steel worksurface	59.05 x 29.52	1650 lbs	836721-74
Lower shelf	53.93 x 25.51	220 lbs	92435012
Spacer bar	59.05-88.58		836451-35

1 Workshop™ Worksurfaces

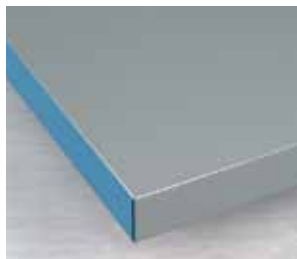

Workshop™ Steel Worksurface

Steel top 1/16 inch
 Painted dark-grey surface
 Blue plastic end edges
 Plywood and chipboard core
 Threaded bushings for attaching legs
 and drawer units
 1/8 inch steel top available on request
 Overall thickness of 1.96 inches

Workshop™ worksurfaces

Steel worksurface .059 inches

Order No.	Size (W x D)	max lbs
836720-74	40" x 30"	1650
836721-74	60" x 30"	1650
836736-74	80" x 30"	1650
836722-74	88.58" x 30"	1100



Structure of the worksurface

The worksurface is an important part of a table's load capacity. The Workshop™ worksurface structure is designed to work in conjunction with the legs and drawers to create a heavy duty system to support very heavy loads. The feet and drawers are attached to the worksurface by integrated threaded bushings.

2 Workshop™ Worksurface Support

• = In stock products

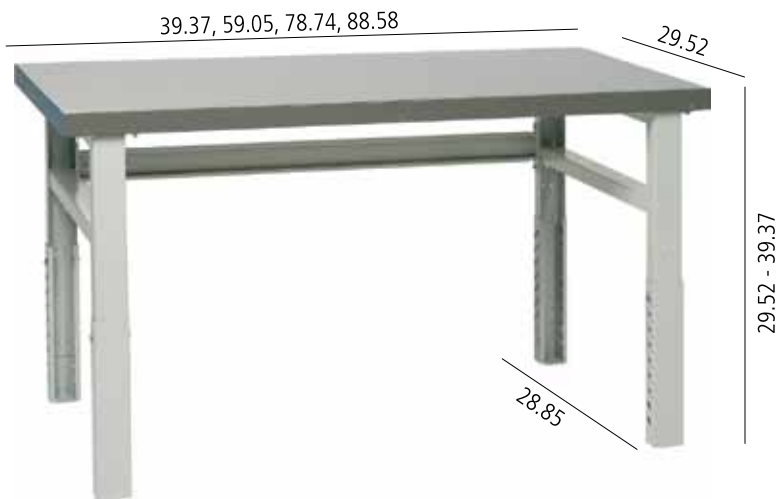

Please see product specification on page 120 for more dimensions.

Workshop™ legs

name	height inches*	order No
Adjustable leg	27.55-37.40	836664-35 •
Fixed leg	31.49	836303-35

* Height excluding top.

The W x D x H rule

All our dimensions follow a WDH rule, where the first dimension is the width (W), the middle the depth (D), and the last the height (H).

3 Spacer bar/Upright attachment frame

Spacer bar

width inches	order No
39.37-59.05	852694-35 •
59.05-88.58	836451-35

Upright attachment frame

Upright attachment frame is needed if the table is configured with slotted uprights. Replaces the spacer bar. Module spacing between mounting locations.

width inches	order No
39.37	852693-35
59.05	860375-35 •
78.74	860725-35
88.58	860376-35

4 Accessories

See pages 34-61 for our wide range of workstation accessories.



The Workshop™ table can be configured with a lower shelf for bulky items.

Lower shelves for the Workshop™ table

name	size W x D inches	max load lbs	order No
Lower shelf for adjustable leg for table 60	53.93 x 29.51	440	92435012
Lower shelf for fixed leg for table 60	53.93 x 29.51	440	92435014
Lower shelf for adjustable leg for table 80	73.62 x 29.51	220	92435013
Lower shelf for fixed leg for table 80	73.62 x 29.51	220	92435015
Lower shelf for adjustable leg for table 88	83.46 x 29.51	220	92435016
Lower shelf for fixed leg for table 88	83.46 x 29.51	220	92435018

The lower shelves include a backstop.



Accessories provide increased functionality

Well-chosen accessories optimize workstation functionality and increase usability. When a workstation is well-organized and well-equipped,

workflow becomes easier and more efficient, improving ergonomics and making it easier to keep tools in place.

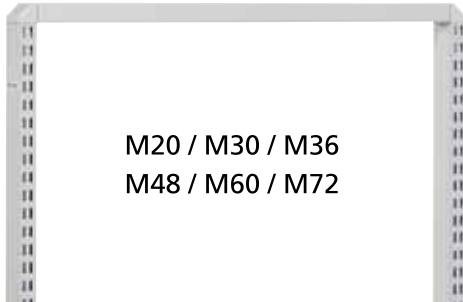

M20 / M30 / M36
M48 / M60 / M72

Single Bay Upright

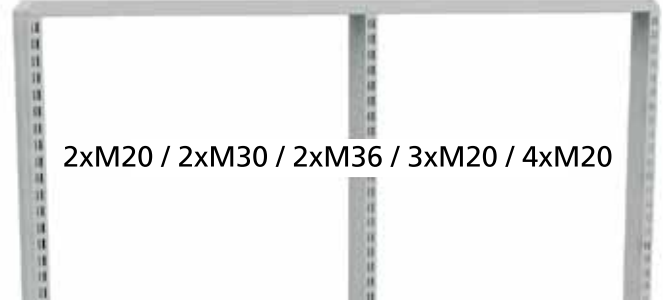

2xM20 / 2xM30 / 2xM36 / 3xM20 / 4xM20

Double / Triple / Quad Bay Upright

Slotted Uprights

Heights inches	Order No
19.09*	860142-35
27.17*	860367-35
41.54*	860024-35
50.20*	860025-35

Installation brackets for Cornerstone™ bench 852581-35

*The shelving uprights height from a 1" thick top surface.

- The Cornerstone™ lab bench frame has module spacing between mounting locations for the upright.
- Double slotted shelving uprights are height adjustable on 1" centers allowing maximum flexibility.

Frame Mounted Upright Modules

Bay/height	Single Bay / Double Bay Order No.
Upright module M30/53	90035001 / 90335001
Upright module M30/63	90035002 / 90335002
Upright module M36/53	90135001 / 90435001
Upright module M36/63	90135002 / 90435002
Upright module M48/53	14-9073501
Upright module M48/63	14-907350
Upright module M53/53	14-9073510
Upright module M53/63	14-9073511
Upright module M60/53	14-9073508
Upright module M60/63	14-9073512
Upright module M72/53	14-9073509
Upright module M72/63	14-9073513

Bench Mounted Shelving Upright Modules

Description	Length(inches)	Order No.
Retrofit Upright Tube w/left foot	53.50	14-9553561
Retrofit Upright Tube w/center foot	53.50	14-9553563
Retrofit Upright Tube w/right foot	53.50	14-9553562

Bay/height	Single Bay / Double Bay Order No.
Upright module M30/53	14-9553501 / 14-9553505
Upright module M30/63	14-9553502 / 14-9553506
Upright module M36/53	14-9553503 / 14-9553521
Upright module M36/63	14-9553504 / 14-9553507

Module size

The module (M) size refers to the nominal distance between two slotted uprights from the middle of the tube. The module size is used to find the appropriate accessories.



Frame Mounted Upright Modules



Bench Mounted Shelving Uprights

Optimize Lab Productivity

When your lab bench is well-planned and well-equipped, workflow becomes easier and more efficient - improving ergonomics and making it easier to keep everything organized.

Shelves

Our extensive range of shelves includes various component sizes that will complete your lab bench. Adjustable shelves enable more ergonomic reach zones and efficient use of storage space.

Steel Shelves with Fixed Tilt

Compatible with module	Size W x D in.	Load Capacity Lbs	Order No.
Steel shelf w/lip, M20 0° or 20° angle	12 x 20	110	860804-35
Steel shelf w/lip, M20 0° or 20° angle	16 x 20	110	860805-35
Steel shelf w/lip, M30 0° or 20° angle	12 x 30	110	836028-35
Steel shelf w/lip, M30 0° or 20° angle	16 x 30	110	852770-35
Steel shelf w/lip, M36 0° or 20° angle	12 x 36	110	852283-35
Steel shelf w/lip, M36 0° or 20° angle	16 x 36	110	852769-35
Steel shelf w/lip, M53 0° or 20° angle	12 x 53	110	860787-35
Steel shelf w/lip, M53 0° or 20° angle	16 x 53	110	860788-35



STEEL SHELF



EQUIPMENT SHELF LIP



EQUIPMENT SHELF

Equipment Shelves

Configuration	Size W x D in.	Load Capacity Lbs	Order No.
Steel Equipment Shelf	M30 x 11.81"	176	E816757-35
Steel Equipment Shelf	M30 x 15.74"	176	E816758-35
Steel Equipment Shelf	M36 x 11.81"	176	E816759-35
Steel Equipment Shelf	M36 x 15.74"	176	E816760-35
Steel Equipment Shelf	M48 x 11.81"	176	854480-35
Steel Equipment Shelf	M48 x 15.74"	176	854483-35
Steel Equipment Shelf	M60 x 11.81"	176	854481-35
Steel Equipment Shelf	M60 x 15.74"	176	854484-35
Steel Equipment Shelf	M72 x 11.81"	176	854482-35
Steel Equipment Shelf	M72 x 15.74"	176	854485-35

See pages 35 and 69 in Sovella's Full Line Catalog for additional shelving options.

Equipment Shelf Lips

Configuration	Order No.
M30 x 2" Equipment Shelf Lip	14-94035339
M36 x 2" Equipment Shelf Lip	14-9403556
M48 x 2" Equipment Shelf Lip	14-9403557
M60 x 2" Equipment Shelf Lip	14-94035370
M72 x 2" Equipment Shelf Lip	14-94035294



EXTENDABLE
PRINTER SHELF

Extendable Shelves

Configuration	Size W x D in.	Load Capacity Lbs	Order No.
Printer Shelf	11 x 19.68	66	859060-35
Large Printer Shelf	13.5 x 19.68	66	E819876-35
Extendable Shelf	M30, 15 x 28	66	92535002
Extendable Shelf	M36, 15 x 34	66	92535003
TL Extendable Shelf	M48, 14.2 x 44.8	66	92535005
TL Extendable Shelf	M60, 14.2 x 56.8	66	92535006
TL Extendable Shelf	M72, 14.2 x 68.8	66	92535007



EXTENDABLE SHELF
TOWER LINE

Chem Shelf

Compatible	Size D x H in.	Load Capacity Lbs	Order No.
M30	4.5" x 3.125"	33	14-94235610
M36	4.5" x 3.125"	33	14-94235973
M48	4.5" x 3.125"	33	14-94235646
M60	4.5" x 3.125"	33	14-94235647
M72	4.5" x 3.125"	33	14-94235648



CHEM SHELF



ADJUSTABLE SHELF

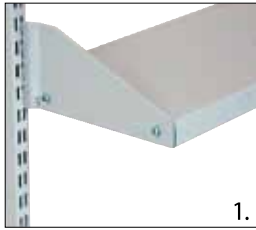

1.



2.



3.



4.

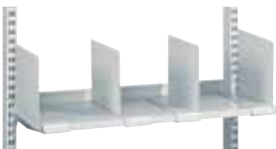

DIVIDER PAIR

Steel Shelves with Fixed Tilt

Compatible	Size W x D in.	Load Capacity Lbs	Order No.
M20	18.5 x 19.88	220	92035001
M20	18.5 x 25.59	220	92035002
M20 stepless depth adjustment	18.5 x 19.88	110	92035003
M20 stepless depth adjustment	18.5 x 25.59	110	92035004
M30	28.35 x 19.88	220	92035005
M30	28.35 x 25.59	220	92035006
M30 stepless depth adjustment	28.35 x 19.88	110	92035007
M30 stepless depth adjustment	28.35 x 25.59	110	92035008
M36	34.25 x 19.88	220	92035009
M36	34.25 x 25.59	220	92035010
M36 stepless depth adjustment	34.25 x 19.88	110	92035011
M36 stepless depth adjustment	34.25 x 25.59	11	92035012

*Adjustable shelves can be tilted 0-25°.

Shelf Brackets

1. Standard Bracket provided with Equipment shelves on page 12

2. Shelf bracket for shelving material other than steel. (shelf sold separately)

Name	Size inches	Order No.
Pair of brackets	12	14-9563523
Pair of brackets	16	14-9563524

3. Top mount shelf brackets for shelving material other than steel. (shelf sold separately)

Name	Size inches	Order No.
Pair of brackets	12	14-9563519
Pair of brackets	16	14-9563521

4. Bookend shelf bracket for equipment shelves and shelving material other than steel. (shelf sold separately)

Name	Size inches	Order No.
Pair of brackets	12	E815050-35
Pair of brackets	16	E816296-35

5. Bottom shelf bracket. (shelf sold separately)

Name	Load Capacity	Size inches	Order No.
Pair of brackets	120 lbs	24	859030-35



5.

Divider pair for the steel shelf

Name	Size W x D in.	Order No.
Divider pair for fixed tilt steel shelf	11.22 x 7.48	010004-35
Divider pair for fixed tilt steel shelf	15.16 x 7.48	010005-35
Divider pair for equipment shelf	11.22 x 7.48	861116-35

Printer/Equipment Platforms

Name	Size inches	Load Capacity Lbs	Order No.
Printer/Equipment Platform stationary, left from upright	15.74 x 19.68	88	92641001
Printer/Equipment Platform stationary, right from upright	15.74 x 19.68	88	92641002
Printer/Equipment Platform Extendable	11.02 x 19.68	66	859060-35
Printer/Equipment Platform Extendable, large	13.50 x 19.68	66	819876-35



Arms ease the installation of accessories on the slotted uprights at the lab bench. The arm loading capacities are between 11-66 lbs.

For Documentation

Name	Size W x D in.	Load Capacity Lbs	Order No.
Document holder	11.42 x 12.99	11	92835008
Document holder	16.46 x 12.99	11	92835009



Supplies/Equipment Trays

Name	Size W x D x H in.	Load Capacity Lbs	Order No.
Supplies tray	9.84 x 9.84 x 3.54	22	92835001
Supplies tray	19.68 x 9.84 x 4.92	33	92835002
Equipment tray	22.04 x 6.88 x 4.92	33	92835005
Equipment tray	23.62 x 8.66 x 4.92	33	92835006

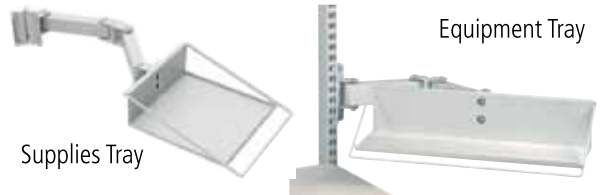

Other Supplies

Name	Order No.
Bottle holder (Ø3.15) for the upright tube	860842-35
Bag holder for the table top lower edge	860840-35
Roll holder for the upright tube (roll Ø height 5.91", width 6.89")	860841-35



Transport skate

With a transport skate, one person can easily move tables. For long distance moving, two transport skates are required. Compatible with tables with a max. depth of 30 inches.

Name	Load capacity lbs	Order No.
Transport skate (sold as each)	396	854061-41



Caster sets

Name	Ø inches	H inches	Hardware	Order No.
Caster set, Ergo and Worktop Lab Carts	3.94	4.92	M10	852768-00
*Caster set, Lab Carts 1 & 2	3.94	5.63	M10	834734-00
Caster set, Heavy-duty Lab Cart	6.30	7.64	Collar	852709-00
*Caster set, Low Profile, non-locking	2.00	2.87	M12	14-7000001
*Caster set, Low Profile, locking	2.00	2.87	M12	14-7000002
*Caster set, Roll & Set (each)	1.96	3.31	M12	14-94035248

*Concept, Cornerstone, and TL Advantage Lab Benches can be equipped with above casters with an M12 attachment hardware.



Lab caster



Low Profile caster



Roll & Set caster

Back Panels/Modesty Panel

Configuration	Order No.
Back panel/Modesty panel TLA M30 x 15.74"H	851892-35
Back panel/Modesty panel TLA M36 x 15.74"H	860292-35
Back panel/Modesty panel TLA M48 x 15.74"H	E816279-35
Back panel/Modesty panel TLA M53 x 15.74"H	E819278-35
Back panel/Modesty panel TLA M60 x 15.74"H	E819277-35
Back panel/Modesty panel TLA M72 x 15.74"H	E819276-35

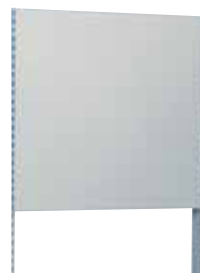

Utility Management



Attached to the slotted upright tubes, the horizontal cable trough enables you to hide the cables at the top of the lab bench.

Cable Troughs

Name	Size W x D x H in.	Order No.
Horizontal cable trough M30	29.02 x 3.82 x 1.77	854553-35
Horizontal cable trough M36	35.04 x 3.82 x 1.77	854554-35
Horizontal cable trough M48	46.73 x 3.82 x 1.77	854555-35
Horizontal cable trough M60	58.54 x 3.82 x 1.77	854556-35
Horizontal cable trough M72	70.59 x 3.82 x 1.77	854557-35

Utility Chases

Name	Order No.
53" Service chase w/3 gas cutouts and cable channel	14-94235555
53" Service chase w/2 duplex comm ports and cable channel	14-94235556
53" Service chase w/2 duplex power receptacles, 10" cord, TL plug, and cable channel	14-94235558
63" Service chase w/3 gas cutouts and cable channel	14-94235604
63" Service chase w/2 duplex commports and cable channel	14-94235605
63" Service chase w/2 duplex power receptacles, 10" cord, TL plug, and cable channel	14-94235607

*Each chase contains 2 independent channels.

Service Chases



Vertical Energy Rails

6 outlet power bar with clamp	14-9113528
6 outlet power bar with clamp, surge	14-9113529
12 outlet power bar with clamp	14-9113530
12 outlet power bar with clamp, surge	14-9113531

Horizontal Energy Rails

Width	Order No.
M30 Bin rail w/6 outlet power	14-9113505
M30 Bin rail w/6 outlet power, surge	14-9113506
M30 Bin rail w/12 outlet power	14-9113507
M30 Bin rail w/12 outlet power, surge	14-9113508
M36 Bin rail w/6 outlet power	14-9113510
M36 Bin rail w/6 outlet power, surge	14-9113511
M36 Bin rail w/12 outlet power	14-9113512
M36 Bin rail w/12 outlet power, surge	14-9113513
M48 Bin rail w/6 outlet power	14-9113515
M48 Bin rail w/6 outlet power, surge	14-9113516
M48 Bin rail w/12 outlet power	14-9113517
M48 Bin rail w/12 outlet power, surge	14-9113518
M53 Bin rail w/6 outlet power	14-91135270
M53 Bin rail w/6 outlet power, surge	14-91135271
M53 Bin rail w/12 outlet power	14-91135257
M53 Bin rail w/12 outlet power, surge	14-91135272
M60 Bin rail w/6 outlet power	14-9113519
M60 Bin rail w/6 outlet power, surge	14-9113520
M60 Bin rail w/12 outlet power	14-9113521
M60 Bin rail w/12 outlet power, surge	14-9113522
M72 Bin rail w/6 outlet power	14-9113523
M72 Bin rail w/6 outlet power, surge	14-9113524
M72 Bin rail w/12 outlet power	14-9113525
M72 Bin rail w/12 outlet power, surge	14-9113526

LED Lighting

LED lights can be mounted to any Light/Balancer rail with included hardware. An additional Universal hardware kit may be purchased for installation on many competitive brands of work stations. LED Tube lights with magnetic attachment option allow lights to be attached under metal surfaces, such as shelves.

Connect up to 8 LED light fixtures to one power source using included connectors. Lights include frosty diffuser cover, power input on sides and top, on/off switch and 13 ft power cord.



Light Balancer Rails

Configuration	Order No.
Light / Balancer rail, front mount, M30, 2 ea 30" tracks	91835004
Light / Balancer rail, front mount, M36, 2 ea 36" tracks	91835007
Light / Balancer rail, front mount, M48, 48" & 48" track	91835010
Light / Balancer rail, front mount, M53, 2 ea 53" tracks	91835011
Light / Balancer rail, front mount, 2M30 of 3xM20, 2 ea 60" tracks	91835006
Light / Balancer rail, front mount, 2M36, 2 ea 72" tracks	91835008



Single LED Light Fixture



Dual LED Light Fixture

LED Lights

Configuration	Description	Dimensions	Power	Order No.
Single	24" single type LED light fixture, light balancer rail hardware	23x1-5/8x1-5/8	9W810Lm6000~6500K	14-9503595
Single	36" single type LED light fixture, light balancer rail hardware	35x1-5/8x1-5/8	12W1080Lm6000~6500K	14-95035102
Single	48" single type LED light fixture, light balancer rail hardware	47x1-5/8x1-5/8	18W 1620Lm6000~6500K	14-9503596
Dual	24" dual type LED light fixture, light balancer rail hardware	22-1/4x1-3/4x1-1/2	15W 1350Lm6000~6500K	14-9503598
Dual	36" dual type LED light fixture, light balancer rail hardware	35.5x1.75x1.5	25W 2250Lm6000~6500K	14-95035119
Dual	48" dual type LED light fixture, light balancer rail hardware	46x1-3/4x1-1/2	30W 2700Lm6000~6500K	14-9503599
Single Magnetic	24" single type LED light fixture, with magnetic attachment	23x1-5/8x1-5/8	9W810Lm6000~6500K	14-95035103
Single Magnetic	36" single type LED light fixture, with magnetic attachment	35x1-5/8x1-5/8	12W1080Lm6000~6500K	14-95035118
Single Magnetic	48" single type LED light fixture, with magnetic attachment	47x1-5/8x1-5/8	18W 1620Lm6000~6500K	14-95035121
Dual Magnetic	24" dual type LED light fixture, with magnetic attachment	22-1/4x1-3/4x1-1/2	15W 1350Lm6000~6500K	14-95035100
Dual Magnetic	36" dual type LED light fixture, with magnetic attachment	35.5x1.75x1.5	25W 2250Lm6000~6500K	14-95035120
Dual Magnetic	48" dual type LED light fixture, with magnetic attachment	46x1-3/4x1-1/2	30W 2700Lm6000~6500K	14-95035101
Hardware	UniFit Universal Light mounting hardware kit (to attach light to other bench mfg)	-----	-----	14-95035110
Hardware	Extension cable, 18" female-to-female	18"L	-----	14-95035111
Hardware	Extension cable, 18" male-to-female	18"L	----	14-95035124
Hardware	Magnetic hardware kit for single and dual LED lights	-----	-----	14-94100221
Hardware	28mm Pipe mounting hardware kit	----	----	14-94100217

Footrests

Configuration	Order No.
Foot rest, free standing, fixed height	JT2
Foot rest, free standing	860137-35
Foot rest, mounts to space bar	14-94235533
Foot rest, bar mount	860136-35

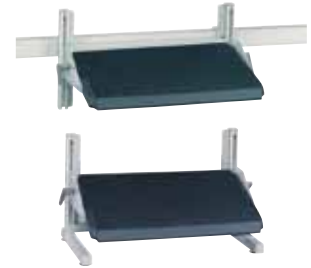

Color Stripes

Color can be added to TL Advantage product table legs with color accent stripes. There are two standard colors, blue and red.

Color	Size Inches	Order No.
blue	72.83 x 3.14	E819285-00
red	72.83 x 3.14	E819287-00



Cabinets

Configuration	Size Inches	Load Capacity Lbs	Order No.
1) Sliding door cabinet, M30	28.34 x 14.56 x 15.74	88	860970-35
2) Overhead Flipper door cabinet, M30	29.25 x 13 x 15.68	88	E811562-35
Overhead Flipper door cabinet, M36	35.37 x 13 x 15.68	88	E810650-35
3) File cabinet with two shelves, M30	28.34 x 12.99 x 35.43	132	860980-35
4) CPU cabinet	12.79 x 21.65 x 22.04	88	861120-35

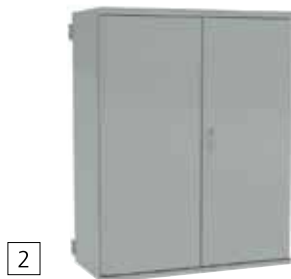

Drawers

Configuration	Size WxDxH	Load Capacity Lbs	Order No.
Drawer unit, 1 lock	11.81"x17.20"x5.91"	22	859330-35
Drawer unit, 1 lock	11.81"x17.20"x8.74"	44	859340-35
Drawer and cabinet, 1x5" drawer and 1x12" cabinet, 14" wide, 1 lock		55	860972-35
Drawer unit 38, 2x3.94"		132	60535001
Drawer unit 45/56-4, 1x3.94", 2x7.87"		330	60635104
Drawer unit 45/56-10, 100% opening, w/o base, 2-3.97" drawers & 11.81" file drawer		330	60635110
Drawer attachment bracket kit, Concept Motor and TL Advantage			854463-35



Drawer brackets

	24 inches	30 inches	36 inches
Concept Lab Bench	860931-35	860930-35	860239-35
Concept Lab Bench with crank		860930-35	
Workshop Lab Bench		870811-00	
Cornerstone Lab Bench	E820347-35	E820348-35	E820349-35



*See page 49 in Sovella's Full Line Product Catalog for additional series 45 drawer configurations.

Monitor, LCD, CPU, and Keyboard Tray Accessories

Configuration	Size	Load Cap. Lbs	Order No.
1) Holder extension for large arm, used with TLA frames	2.36"L		861099-35
2) LCD (flat screen) monitor arm, double articulating arm (for 75mm and 100mm hole pattern)		33	93035002
3) Keyboard tray for LCD (flat screen) monitor holder	19"W x 10.23"D	11	860941-35
4) Keyboard and mouse tray, for LCD (flat screen) monitor holder	24"W x 10.23"D	11	860942-35
5) Under surface keyboard shelf	24.8" x 15.74"	22	92535001
6) Articulating keyboard			14-94235068
7) Height adjustable arm with bracket (for 75mm and 100mm hole pattern)		33	14-9413565
8) CPU holder bar clamp, basic upright frame and TL Advantage series	5.9" x 19.68" x 3.34"		14-94235532
8) CPU holder, bar clamp	5.9" x 19.68" x 3.34"		860740-35
9) CPU holder, leg mount, Concept	7.09"-8.86"x17.72"x1.96"	44	860557-35
9) CPU holder, foot clamp, motor	7.09"-8.86"x17.72"x1.96"	44	860740-35



Chairs and Stools

name	height adj	Back dimension	Seat dimension	Order No
1 V4 Series Upholstered Chair, glides	16"-21"	16"W x 15"D	18"W x 18"D	14-2000152 (black)
V4 Series Upholstered Chair, glides	16"-21"	16"W x 15"D	18"W x 18"D	14-2000153 (blue)
V4 Series Upholstered Chair, glides	16"-21"	16"W x 15"D	18"W x 18"D	14-2000154 (gray)
V4 Series Upholstered Chair, carpet casters	17"-22"	16"W x 15"D	18"W x 18"D	14-2000155 (black)
V4 Series Upholstered Chair, carpet casters	17"-22"	16"W x 15"D	18"W x 18"D	14-2000156 (blue)
V4 Series Upholstered Chair, carpet casters	17"-22"	16"W x 15"D	18"W x 18"D	14-2000157 (gray)
V4 Series Upholstered Chair, floor casters	17"-22"	16"W x 15"D	18"W x 18"D	14-2000158 (black)
V4 Series Upholstered Chair, floor casters	17"-22"	16"W x 15"D	18"W x 18"D	14-2000159 (blue)
V4 Series Upholstered Chair, floor casters	17"-22"	16"W x 15"D	18"W x 18"D	14-2000160 (gray)
V4 Series Upholstered Chair, footring, glides	23"-33"	16"W x 15"D	18"W x 18"D	14-2000161 (black)
V4 Series Upholstered Chair, footring, glides	23"-33"	16"W x 15"D	18"W x 18"D	14-2000162 (blue)
V4 Series Upholstered Chair, footring, glides	23"-33"	16"W x 15"D	18"W x 18"D	14-2000163 (gray)
V4 Series Upholstered Chair, footring, carpet casters	24"-34"	16"W x 15"D	18"W x 18"D	14-2000164 (black)
V4 Series Upholstered Chair, footring, carpet casters	24"-34"	16"W x 15"D	18"W x 18"D	14-2000165 (blue)
V4 Series Upholstered Chair, footring, carpet casters	24"-34"	16"W x 15"D	18"W x 18"D	14-2000166 (gray)
V4 Series Upholstered Chair, footring, floor casters	24"-34"	16"W x 15"D	18"W x 18"D	14-2000167 (black)
V4 Series Upholstered Chair, footring, floor casters	24"-34"	16"W x 15"D	18"W x 18"D	14-2000168 (blue)
V4 Series Upholstered Chair, footring, floor casters	24"-34"	16"W x 15"D	18"W x 18"D	14-2000169 (gray)
2 V7 Series Polyurethane Chair, glides	17"-22"	17"W x 12"D	18"W x 17"D	14-2000171
V7 Series Polyurethane Chair, carpet casters	18"-23"	17"W x 12"D	18"W x 17"D	14-2000172
V7 Series Polyurethane Chair, floor casters	18"-23"	17"W x 12"D	18"W x 17"D	14-2000173
V7 Series Polyurethane Chair, glides, footring	22"-32"	17"W x 12"D	18"W x 17"D	14-2000174
V7 Series Polyurethane Chair, carpet casters, footring	23"-33"	17"W x 12"D	18"W x 17"D	14-2000175
V7 Series Polyurethane Chair, floor casters, footring	23"-33"	17"W x 12"D	18"W x 17"D	14-2000176
3 V8 Series ESD Chair, glides	16"-21"	16"W x 15"D	18"W x 18"D	14-2000177
V8 Series ESD Chair, floor casters	17"-22"	16"W x 15"D	18"W x 18"D	14-2000178
V8 Series ESD Chair, glides and adj. footring	20"-27.5"	16"W x 15"D	18"W x 18"D	14-2000179
V8 Series ESD Chair, floor casters, adj footring	21"-28.5"	16"W x 15"D	18"W x 18"D	14-2000180
V8 Series ESD Chair, glides, adj footring	23"-33"	16"W x 15"D	18"W x 18"D	14-2000181
V8 Series ESD Chair, floor casters, adj footring	24"-34"	16"W x 15"D	18"W x 18"D	14-2000182
4 Sit Stand Stool	25" - 34"	n/a	13"w, 12"d	14-2000063
5 Series X 30	16.73" - 22.24"	14.57"w, 10.83"h	17.91"w, 17.52"d	X30B (blue)
Series X 30	16.73" - 22.24"	14.57"w, 10.83"h	17.91"w, 17.52"d	X30G (grey)
Series X 30	16.73" - 22.24"	14.57"w, 10.83"h	17.91"w, 17.52"d	X30GESD (black)
6 Anti-bacterial Saddle Chair, 265 lb cap.	22.64"-32.28"	n/a	19.5" diameter	Saddle AL Antib



*Armrest options available.

Treston Storage Cabinets

• = In stock products

Cabinets, which combine a stylish industrial design with practical accessories to provide flexible and efficient small parts storage. Available in two cabinet sizes, 21.65" and 11.42" high. A compact storage system: one cabinet offers storage for up to 360 different

items. Designed with drawer handles recessed within the frame for additional protection during transport. The cabinets can be wall mounted, placed on the worksurface, or mounted on space-saving turntables.

Visible Storage Cabinet - Series 290

Order No.	Drawer Type (qty/cabinet)	Width dividers* (qty/drawer)	Length Dividers* (qty/drawer)
290-3	L-00 (30 pcs)	V-00 (5 pcs)	---
291-3	L-01 (24 pcs)	V-01 (5 pcs)	V-012 (1 pcs)
292-3	L-02 (12 pcs)	V-02 (5 pcs)	V-012 (3 pcs)
294-3	L-04 (12 pcs)	V-04 (5 pcs)	V-0456 (1 pcs)
296-3	L-06 (4 pcs)	V-06 (5 pcs)	V-0456 (5 pcs)
297-3	L-07 (6 pcs)	V-07 (5 pcs)	V-078 (3 pcs)
290C-3	L-01 (12 pcs)	V-01 (5 pcs)	V-012 (1 pcs)
	and L-04 (3 pcs)	and V-04 (5 pcs)	and V-0456 (1 pcs)
	and L-06 (1 pcs)	and V-06 (5 pcs)	and V-0456 (5 pcs)

*Dividers sold separately.



Series 290

Series 550

Visible Storage Cabinet - Series 550

Order No.	Drawer Type (qty/cabinet)	Width dividers* (qty/drawer)	Length Dividers* (qty/drawer)
550-3	L-00 (60 pcs)	V-00 (5 pcs)	---
551-3	L-01 (48 pcs)	V-01 (5 pcs)	V-012 (1 pcs)
552-3	L-02 (24 pcs)	V-02 (5 pcs)	V-012 (3 pcs)
554-3	L-04 (24 pcs)	V-04 (5 pcs)	V-0456 (1 pcs)
556-3	L-06 (8 pcs)	V-06 (5 pcs)	V-0456 (5 pcs)
557-3	L-07 (12 pcs)	V-07 (5 pcs)	V-078 (3 pcs)
550C-3	L-01 (24 pcs)	V-01 (5 pcs)	V-012 (1 pcs)
	and L-04 (6 pcs)	and V-04 (5 pcs)	and V-0456 (1 pcs)
	and L-06 (2 pcs)	and V-06 (2 pcs)	and V-0456 (5 pcs)

*Dividers sold separately.



Small Parts Drawers

The crystal clear drawers are transparent, allowing visual identification. Each drawer has a corrugated base to simplify picking. A large, sturdy handle provides a full width label area. Optional accessories: width and length dividers.

Small Parts Drawers

Order No.	Size (D x W x H) (outer dimensions)	Size (D x W x H) (inner dimensions)
L-00	6.89" x 2.17" x 1.46"	5.75" x 1.85" x 1.26"
L-01	6.89" x 2.72" x 1.46"	5.75" x 2.40" x 1.26"
L-02	6.89" x 5.43" x 1.46"	5.75" x 5.04" x 1.26"
L-04	6.89" x 3.62" x 2.32"	5.75" x 3.23" x 2.17"
L-06	6.89" x 10.91" x 2.32"	5.75" x 10.47" x 2.17"
L-07	6.89" x 5.43" x 3.19"	5.75" x 5.04" x 2.91"



*Dividers sold separately.

Spacemisers™

Perfect for storage and identification of thousands of small components. Such assemblies offer storage for up to 4320 different items on a floor area of only 2.7 sq ft.

Spacemiser

This unit includes a ball bearing base and dividing trays. The assembly holds 12 visible storage cabinets from series 550 in three layers. Each layer consist of four cabinets which are ordered separately. Load capacity 880 lbs. Benchtop version (PTP-5) holds 2 visible storage cabinets from series 290 or 500, sold separately.

Order No.	Size (D x W x H)
12-550	19.69" x 19.69" x 68.11"
12-550ESD*	19.69" x 19.69" x 68.11" 
PTP-5	12.20" x 14.17" x 11.81" (series 290)
PTP-5	12.20" x 14.17" x 22.05" (series 550)
PTP-5ESD* •	12.20" x 14.17" (x 11.81" H with cabinet series 290, 22.05" H with cabinet series 550) 

*Includes ground cord.



Storage Solutions

Shelves are necessary to keep the laboratory organized. Our flexible Sovella® lab shelves offer unique and user-friendly storage solutions. The Sovella® shelving system is built for maximum storage capability and ease of installation. Shelves may be easily adjusted without the use of tools.

Assemble your Sovella® Shelving System

Select a suitable frame for the shelving system.



Horizontal rail attached to the wall

- Select a suitable oval horizontal rail length for the space in use and the need for shelf width.
- Rails may be joined together to add seamless extensions.
- Attach the oval rail at an appropriate height using hardware suitable for the wall material.
- Hang the vertical upright on the oval horizontal rail and slide to the desired width.

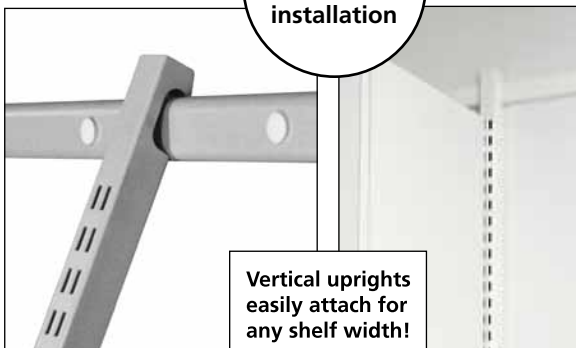

Oval horizontal rail, 660 lbs/40"

Name	Size inches	Order No.
Oval horizontal rail	96	E816365
Oval horizontal rail	48	E816366
Upright tube for oval horizontal rail	47.24	100071
Upright tube for oval horizontal rail	78.74	100070
Cover plugs and end plugs		010014
Extension piece for oval horizontal rail		110913

Oval horizontal rail We recommend the oval horizontal rail for very heavy loads (660 lbs/40").



Wall standard without support rail

Name	Size inches	Order No.
Wall standard	5.91	011546
Wall standard	19.69	011554
Wall standard	39.37	001589
Wall standard, stainless steel	39.37	111032
Wall standard	59.06	001597
Wall standard	78.74	001619
Wall standard, stainless steel	78.74	111034
Wall standard	88.58	110943
Wall standard	98.42	011627



Brackets

Name	Size inches	Load Capacity Lbs	Order No.
1) Bracket	5.90	264	001961
	7.87	220	001988
	9.84	176	001996
	11.81	154	002003
	13.77	132	002011
2) Bracket, strengthened	15.74	264	001678
	17.71	220	001686
	19.68	176	001694
3) Bracket frame, straight/slanted 18°	21.65	154	001708
	11.81	132	558206
Pair of brackets, stainless steel	11.81	264	111023
Pair of brackets, stainless steel	15.75	264	111024
4) Bracket frame, straight	19.69	220	558222
4) Bracket frame, straight	23.62	264	558249

*Additional shelving options available on pages 12 and 13.



Wall standard without support rail

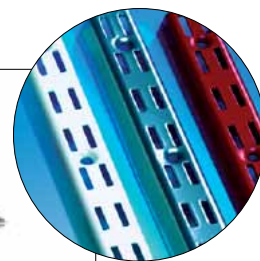
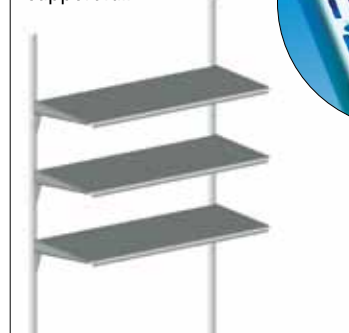

Brackets



See page 12 for a variety of shelves, additional brackets and shelving accessories.

Reagent Rack Systems

Flexible center shelving system for renovations and new construction.

Features:

- Shelving lengths of 20", 30", 36", 48", 60", 72", and depths of 12", and 16".
- Several bracket options to include undermount/overmount bookend
- Shelf lips in rear/front



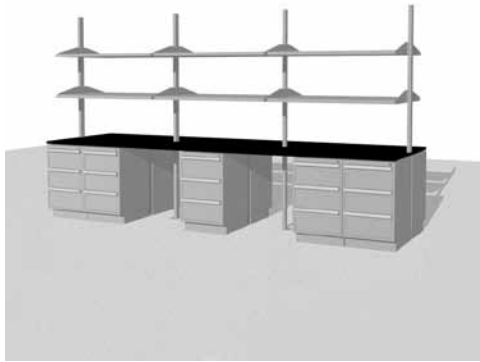

Front mounted Reagent rack

Through counter	30"W	36"W	48"W
Shelf Bay	14-9563501	14-9563502	14-9563503
Shelf Extension	14-9563504	14-9563505	14-9563506

Shelf Bay Includes:

2 pcs Uprights 78"
 2 pcs Mounting brackets
 1 pc Top cross rail
 2 pcs Corners

Shelf Bay Extension Includes:

1 pc Upright 78"
 1 pc Mounting bracket
 1 pc Top cross rail
 1 pc T bracket

Please reference the accessories pages 12-18 for shelves, shelf brackets, and other accessories.



Top mounted Reagent rack

counter mounted	30"W	36"W	48"W
Shelf Bay	14-9563507	14-9563508	14-9563509
Shelf Extension	14-9563510	14-9563511	14-9563512

Shelf Bay Includes:

2 pcs Uprights 39"
 2 pcs Mounting brackets
 1 pc Top cross rail
 2 pcs Corners

Shelf Bay Extension Includes:

1 pc Upright 39"
 1 pc Mounting bracket
 1 pc Top cross rail
 1 pc T bracket

The shelf upright shown are standard. Other heights available upon request. Please reference the accessories pages 12-18 for shelves, shelf brackets, and other accessories.



Top mounted Reagent rack with center shelf

Double side with center shelf	30"W	36"W	48"W
Shelf Bay	14-9563513	14-9563514	14-9563515
Shelf Extension	14-9563516	14-9563517	14-9563518

Shelf Bay Includes:

2 pcs Uprights 39"
 2 pcs Mounting brackets
 1 pc Top cross rail
 2 pcs Corners

Shelf Bay Extension Includes:

1 pc Upright 39"
 1 pc Mounting bracket
 1 pc Top cross rail
 1 pc T bracket

The shelf upright shown are standard. Other heights and widths available upon request. Please reference the accessories pages 12-18 for shelves, shelf brackets, and other accessories.



Freedom of Mobility

Work is not always confined to a single lab, and you must be able to move the supplies safely from one lab to another. Lightweight Lab carts are ideal for this situation. Due to their modularity and versatile accessory components, our lab carts provide you with an ergonomic mobile lab cart suitable for any lab environment.

Each lab cart can be customized to suit individual requirements and preferences. They can be configured with all standard modules, such as additional shelves and auxiliary tops. They are equipped with four swivel casters (Ø3.94"), two of which have roll and swivel brakes.



ERGO LAB TROLLEY



WORKTOP LAB TROLLEY

Light Duty Lab Carts

Name	Size WxDxH inches	Load Capacity Lbs	Order No.
Ergo Trolley	29.52 x 19.68 x 25.59-35.43	330	14-C7403562
Worktop Trolley	29.52 x 23.62 x 25.78-41.53	330	14-C7403598
2-Shelf Trolley	21.06" x 35.43" x 39.96"	330	TRTA 4082
2-Shelf Trolley	21.06" x 43.31" x 39.96"	330	TRTA 4102
2-Shelf Trolley	25" x 35.43" x 39.96"	330	TRTA 5082
2-Shelf Trolley	25" x 43.31" x 39.96"	330	TRTA 5102
4-Shelf Trolley	21.06" x 43.31" x 60.43"	660	TRTA 4104
4-Shelf Trolley	25" x 43.35" x 60.43"	660	TRTA 5104

Lab Carts Width

Name	M20	M30	M36
Lab Cart 1	C72135001	C72135002	C72135003
Lab Cart 2	C72235001	C72235002	C72235003



2-SHELF TROLLEY



4-SHELF TROLLEY

Heavy Duty Lab Carts

Heavy duty lab carts, as their name indicates, are ideal for moving heavy loads. Their special casters support extremely heavy weights. The total load capacity of the basic model is up to 1320 lbs! The heavy duty carts are equipped with two fixed casters and two swivel casters with brakes.

Heavy Duty Lab Carts

Name	Size WxDxH inches	Load Capacity Lbs	Order No.
Heavy Duty Lab Cart 1	36.81 x 30.90 x 37	1320	C75041001
Heavy Duty Lab Cart 2	36.81 x 30.90 x 37	1320	C75041002



LAB CART 1



LAB CART 2



HEAVY-DUTY LAB CART 1



HEAVY-DUTY LAB CART 2



Treston Medi is a furniture series that is designed in close collaboration with medical experts. Treston Medi products combines sleek Scandinavian design and furniture care required by the evening special features. Treston's decades of experience as a professional furniture manufacturer, is shown finishing. For cabinets with high quality components that ensure Treston Medi furniture for durability and reliability.

Functional design in terms of ergonomics

Treston Medi-series offers health care professionals in their daily work easier tools. The furnishings are ergonomically designed and have a wide variety of controls. Desktops individual height adjustments allow for good posture. The furnishings are also working in confined spaces, they are light and easy to move. Excellent ergonomics and functionality complement the well thought out and polished design.

Medical Carts

Name	Size WxDxH inches	Order No.
1) Mobile workstation base cart	23.22" x 22.26" x 31.5-47.24"	MLC 405
2) Instrument cart w/ 4 shelves	25.19" x 22.44" x 67.12"	MER 170
3) Treatment cart narrow	25.59" x 25.59" x 66.93"	MTT 605
4) Treatment cart wide	25.59" x 35.43" x 66.93"	MTT 607
5) Suture Cart	25.98" x 25.59" x 57.71"	WTR140
6) Basket Cart	22.44" x 25.2" x 50.39"	MBT 130

Suture Carts

Name	Description	Order No.
Suture Cart 1 - M20	Includes; frame, caster set, 3 adjustable shelves, 5 divider pairs, bottom shelf with mat	14-C74041101
Suture Cart 1 - M30	Includes; frame, caster set, 3 adjustable shelves, 6 divider pairs, bottom shelf with mat	14-C74041102
Suture Cart 1 - M36	Includes; frame, caster set, 3 adjustable shelves, 8 divider pairs, bottom shelf with mat	14-C74041103
Suture Cart 2 - M20	Includes; frame, caster set, 8 adjustable shelves, 12 divider pairs	14-C74041104
Suture Cart 2 - M30	Includes; frame, caster set, 8 adjustable shelves, 16 divider pairs	14-C74041105
Suture Cart 2 - M36	Includes; frame, caster set, 8 adjustable shelves, 22 divider pairs	14-C74041106



SUTURE CARTS

Medical Cart Accessories

Name	Size WxDxH inches	Order No.
Waste Pail	6 liter	WB-6L
Waste Pail	10 liter	WB-10L
Folder Holder	25.19" x 22.44" x 67.12"	FH3
Bottle holder		DH
Monitor arm		MS



Solutions that satisfy even the most demanding lab users!



Technical Lab



ADA motorized Lab bench



Pharmaceutical Lab with motorized Lab benches



Reagent Racks added to existing Lab



Multi-trolley

The Range of Colors

Our products now come in new colors. With our new, even broader range of colors you can customize your equipment to match your corporate colors or existing color schemes in specific lab. Now doors, drawers and perforated panels all come in various colors. Please check the delivery times with our sales representatives for new colors.

Color	Sovella Code	Color Code	Doors	Drawers	Perforated/back panels	System Shelves
Blue	02	NCS 4040	A	A	A	-
Ruby Red	03	RAL 3003	A	A	A	-
Green	04	RAL 6011	A	A	A	-
Royal Blue	07	RAL 5007	STD	A/STD	STD	-
Light Blue	08	RAL 5012	A	A	A	-
Black	18	RAL 9005	A	A	A	A
White	21	RAL 9010	A	A	A	STD
Glacier White	61	RAL 9002	A	A	A	A
Red	25	RAL 3002	-	-	-	A
Antique Copper	31	-	-	-	-	A
Light Grey	35* & 41	RAL 7038	A	A/STD	A/STD	A
Effect Silver Grey	38	AE 4148	A	A	A	STD

*35 is ESD protected light grey; 41 is non-ESD protected. Please remember that ESD protection will result in a slightly darker shade of color than the given RAL cod.

STD = Standard Factory Color, normal warehouse delivery, listed price.

A = Factory color. Check with your sales representative for delivery times and prices.

Tables, cabinet, and drawer frames are light grey (RAL 7038), excluding the blue drawer unit 71 (RAL 5007).

Outside of the standard color range, additional colors are available on request.

Please contact our sales representatives or email us at infousa@sovella.com.

The color code is included in the code number, either at the end, following the hyphen (e.g. steel shelf M20 860804-35), or in the middle (e.g. in the shelving system 100/40/200 C33407000).



Blue (02)



Ruby red (03)

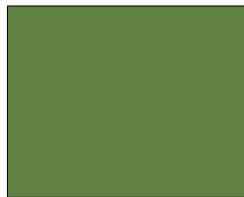

Green (04)



Royal blue (07)



Light blue (08)

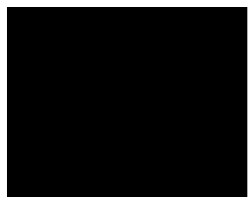

Black (18)



White (21)



Red (25)

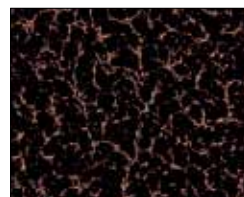

Antique copper (31)

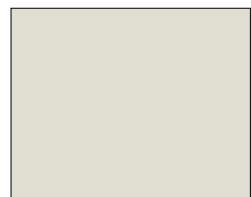

Light grey (35 & 41)



Effect silver grey (38)

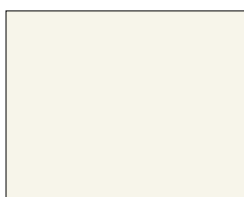

Glacier White (61)

Treston® Storage Bin Colors



crystal clear

Lab Bench Dimensions

Concept™ Lab Benches

- Concept™ bench frame consist of a pair of legs, rear case, and front rail.
- Depth of Concept™ bench frame is 23.62", 29.5" or 35.43" with the use of depth kit.
- Concept™ frames are available in widths: 39.37", 47.24", 59.05", 70.86" and 78.74"
- Table frames can be easily equipped with any 12mm stem caster.

Steel Thickness:

Steels used in the construction of the frames are 12, 14 and 16 gauge CRS steel, except as follows:

- Leg attachment parts: 7 gauge CRS steel
- Cable rail: 20 gauge CRS steel

Concept™ Lab Bench - Manual

- Leg pair Concept™ 30 can support 1100 lb load, evenly loaded.
- Concept™ 30 can be equipped with tilting mechanism. The tilting frame is for width 59.05". Tilting frame is equipped with motor, which can tilt 85 lb load. Maximum tilting angle is 50 degrees.

- Height adjustment of Concept™ 30 frame is 26.62" - 44.34" with table top and adjustment glide. Height adjustment is made by adjusting telescoping legs and tightening friction screws on the back and sides of the legs.

- Bench frames can be easily equipped with any 12mm stem caster.

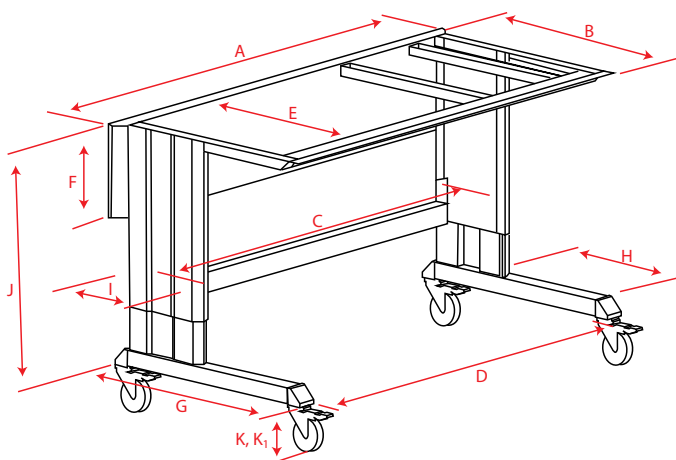

Concept™ Workstation Frame - Manual

	24 x 48	30 x 48	24 x 60	30 x 60	24 x 72	30 x 72
A	47.24"	47.24"	59.06"	59.06"	70.86"	70.86"
B	23.33"	29.07"	23.33"	29.07"	23.33"	29.07"
C	40.78"	40.78"	52.60"	52.60"	64.41"	64.41"
D	40.11"	40.11"	51.93"	51.93"	63.74"	63.74"
E	17.03"	22.93"	17.03"	22.93"	17.03"	22.93"
F	11.43"	11.43"	11.43"	11.43"	11.43"	11.43"
G	23.54"	29.52"	23.54"	29.52"	23.54"	29.52"
H	13.51"	17.57"	13.51"	17.57"	13.51"	17.57"
I	7.93"	11.12"	7.93"	11.12"	7.93"	11.12"
J	26.82-44.34"	26.82-44.34"	26.82-44.34"	26.82-44.34"	26.82-44.34"	26.82-44.34"
K	5.5"	5.5"	5.5"	5.5"	5.5"	5.5"
*K ₁	2.87"	2.87"	2.87"	2.87"	2.87"	2.87"

*K₁ - Low Profile caster option.

Concept™ Workstation - Hand Crank

- Pair of legs of crank frame can support 440 lb dynamic load, and 1100 lb static load, evenly loaded.
- Frames are available in depths of 23.6", 29.5" and 35.43"
- Frames are available in widths of 39.4", 47.2", 59.1" and 71.1".
- Height adjustment of crank frame is 26.6"-40.4" without table top.

- The crank handle can be installed on the left or right side of the frame. Standard table configuration is right hand crank.
- Height adjustment change one inch per each full rotation of the crank handle.
- The crank folds away under the frame when not in use.

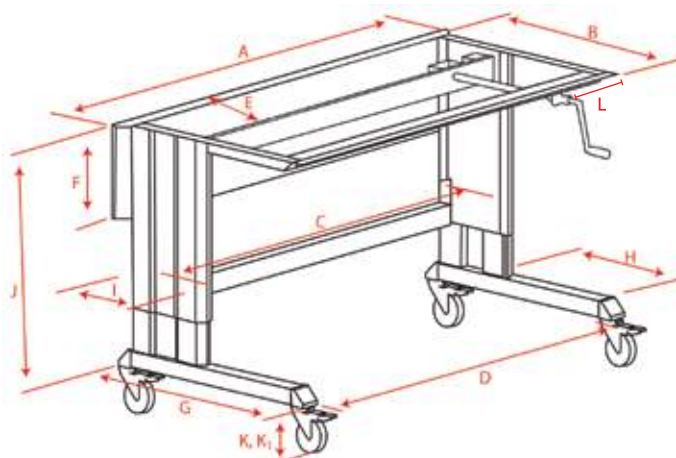

Concept™ Workstation Frame - Hand Crank

	24 x 48	30 x 48	24 x 60	30 x 60	24 x 72	30 x 72
A	47.24"	47.24"	59.06"	59.06"	70.86"	70.86"
B	23.33"	29.07"	23.33"	29.07"	23.33"	29.07"
C	40.78"	40.78"	52.60"	52.60"	64.41"	64.41"
D	40.11"	40.11"	51.93"	51.93"	63.74"	63.74"
E	10.52"	16.44"	10.52"	16.44"	10.52"	16.44"
F	11.43"	11.43"	11.43"	11.43"	11.43"	11.43"
G	23.54"	29.52"	23.54"	29.52"	23.54"	29.52"
H	11"	18.28"	11"	18.28"	11"	18.28"
I	9.26"	9.26"	9.26"	9.26"	9.26"	9.26"
J	26.82-40.60"	26.82-40.60"	26.82-40.60"	26.82-40.60"	26.82-40.60"	26.82-40.60"
K	5.5"	5.5"	5.5"	5.5"	5.5"	5.5"
*K ₁	2.87"	2.87"	2.87"	2.87"	2.87"	2.87"
L	8.06"	8.06"	8.06"	8.06"	8.06"	8.06"

*K₁ - Low Profile caster option.

Concept™ Workstation - Motorized

- Leg pair of Concept™ motorized frame can support a static load of 1100 lbs, evenly loaded on a worktop and a dynamic load of 660 lbs, evenly loaded.
- Frames are available in depths of 23.62", 29.52" and 35.43".
- Frames are available in widths of 39.37", 47.24", 59.05", 70.86" and 78.74"
- Height adjustment range of Concept™ motorized frame is 27.80" - 43.55" with table top and adjustment glides. Adjustment is made with 2 linear actuators, using an up/down memory desk switch.
- The speed of the frame is .70" / sec without load

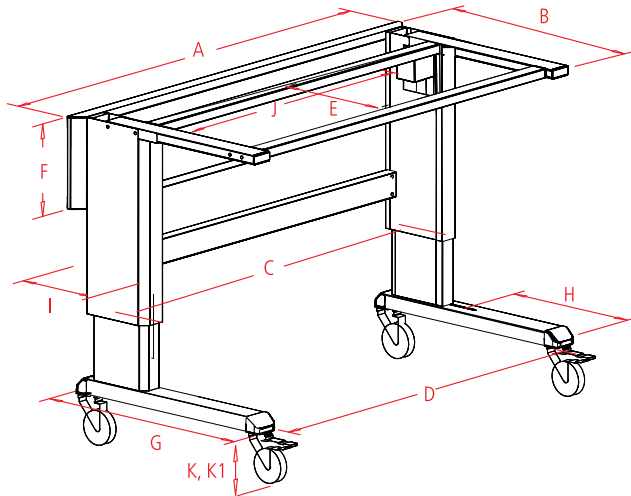

- The speed of the frame is .59" / sec with load
- The desk switch can be installed on the front, left or right side of frame.
- The desk switch has multi position memory system to be able to set the frame to three customer based heights and up-down buttons for random settings.
- All units have soft-start and soft-stop circuitry.
- The table can be manually driven over the memory positions.
- Silent operation (45 db (A) DS/EN ISO 3746
- Capable of operations in ambient temperature 41 to 104 degrees Fahrenheit

Concept™ Workstation Frame - Motorized

	24 x 48	30 x 48	24 x 60	30 x 60	24 x 72	30 x 72
A	47.24"	47.24"	59.06"	59.06"	70.86"	70.86"
B	23.33"	28.66"	23.33"	28.66"	23.33"	28.66"
C	40.78"	40.78"	52.60"	52.60"	64.41"	64.41"
D	40.11"	40.11"	51.93"	51.93"	63.74"	63.74"
E	8.92"	14.72"	8.92"	14.72"	8.92"	14.72"
F	11.43"	11.43"	11.43"	11.43"	11.43"	11.43"
G	23.54"	29.52"	23.54"	29.52"	23.54"	29.52"
H	12.4"	17.57"	12.4"	17.57"	12.4"	17.57"
I	9.36"	9.36"	9.36"	9.36"	9.36"	9.36"
J	31.62"	31.62"	43.53"	43.53"	55.33"	55.33"
K	5.5"	5.5"	5.5"	5.5"	5.5"	5.5"
*K ₁	2.87"	2.87"	2.87"	2.87"	2.87"	2.87"

*K₁ - Low Profile caster option.

TL Advantage™ Workstation

- TLA-worktable™ frame consist of leg pair, spacer bars, worksurface support assembly.
- TLA™ leg pair can support 660 lb load, evenly loaded.
- Depth of TLA™ table frame is 32.87" for single sided frame and 59.05" for double sided frame.
- Frames are available in widths: 49.88", 61.69" and 73.74".
- TLA™ can be extended with extension table frames, widths 49.88", 61.69" and 73.74". These extension table frames can also support 660 lb load, evenly loaded.
- TLA™ can be extended with a corner table frame, 32.87" x

32.87". This corner table frame can support 660 lb load, evenly loaded.

g. Height adjustment of TLA™ worksurface assembly is accomplished by mounting the worksurface assembly at the desired height along the length of the slotted vertical leg. Slots are 1" increments.

Steel Thickness:

Steels used in the construction of the frames are 12, 14 and 16 gauge CRS steel, except as follows:

- Leg attachment components: 7 gauge CRS steel

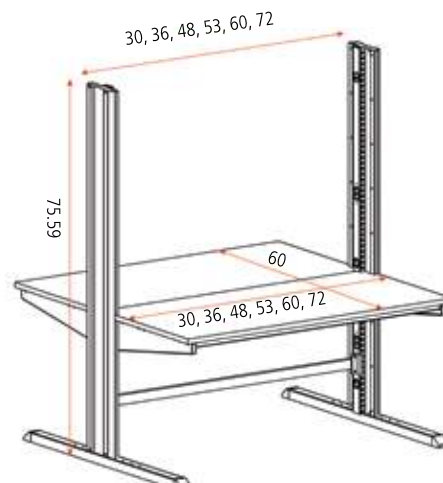
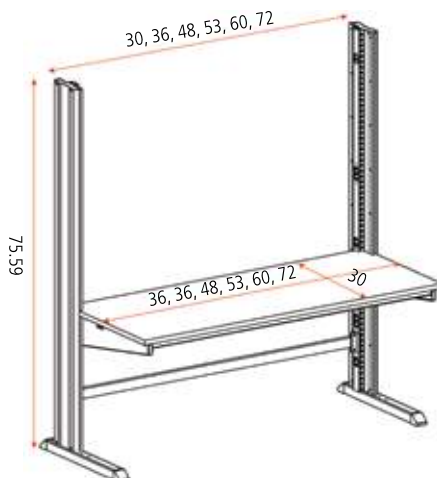

Cornerstone-WS™ Workstation

- Cornerstone-WS™ worktable frame consists of one right and one left lower "H" leg. Upper horizontal front rail and upper horizontal rear structure for structural stability and slotted upright attachment.
- Cornerstone-WS™ worktable frame can support 1500 lb load, evenly loaded.
- Depth of Cornerstone-WS™ worktable frame is 23.62", 29.52" or 35.43"
- Frames are available in widths: 47.24", 59.05", 70.86".
- Height adjustment from 23.5" to 36.39" in 1 inch increments. Telescoping leg parts are set with through bolts.

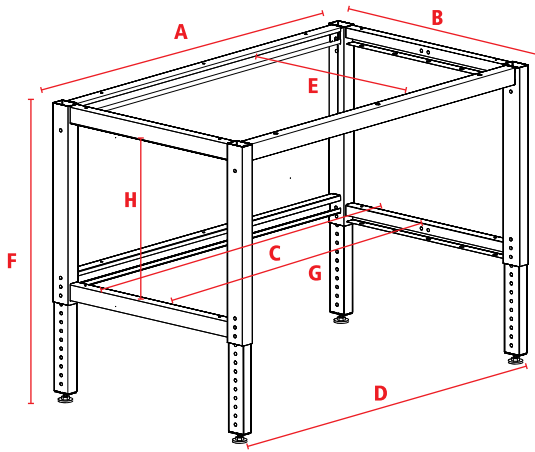

- Table frames can be easily equipped with any 12mm stem casters.
- Slotted upright mounting brackets are included.

Steel Thickness:

Steels used in the construction of the frames are 12, 14 and 16 gauge CRS steel, except as follows:

- Attachment parts for bolts: 7 gauge CRS steel
- Cable rail: 20 gauge CRS steel

Cornerstone-WS™ Workstation Frame

	24 x 48	30 x 48	24 x 60	30 x 60	24 x 72	30 x 72
A	45.81"	45.81"	57.63"	57.63"	69.44"	69.44"
B	21.78"	27.69"	21.78"	27.69"	21.78"	27.69"
C	43.13"	43.13"	54.94"	54.94"	66.75"	66.75"
D	44.19"	44.19"	56"	56"	67.81"	67.81"
E	18.35"	24.25"	18.35"	24.25"	18.35"	24.25"
F	23.5-36.39"	23.5-36.39"	23.5-36.39"	23.5-36.39"	23.5-36.39"	23.5-36.39"
G	45.5"	45.5"	57.31"	57.31"	69.13"	69.13"
H	20"	20"	20"	20"	20"	20"

Workshop™ Workstations

- Adjustable leg set can support 1650 lbs. per leg pair. Height adjustable 27.55" to 37.40" without top.
- Leg depth is 29.52".
- Upright attachment frame available in sizes 39.37", 59.05", 78.74", 88.58".

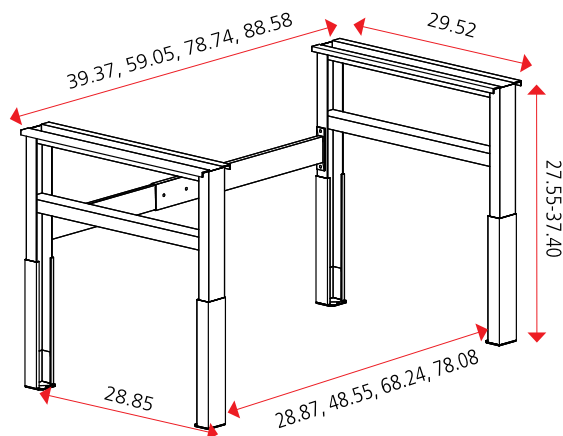

- When uprights are not required, the legs can be connected using spacer bars. Adjustable 39.37" to 59.05" or 59.05" to 88.58".
- Drawer pedestal 55 can take the place of a leg.

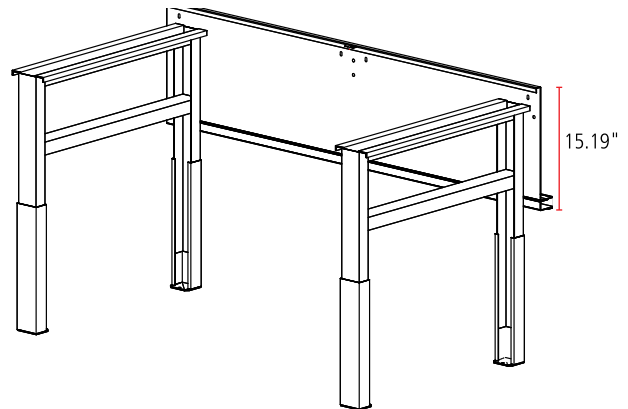



222 S. Main St. 5th Floor, Salt Lake City, UT 84101 |
<https://www.mh-usa.com/> | 800-362-4403